

MOBILE HINGED SUPPORT RAILS

NECESSARY

OPTIONAL
SEPARATELY

Polyamide CE



950.50.11190 | 600 mm 950.50.12190 | 700 mm
950.50.13190 | 850 mm

950.50.11191 | 600 mm 950.50.12191 | 700 mm
950.50.11199 | 600 mm 950.50.12199 | 700 mm
950.50.13191 | 850 mm 950.50.13199 | 850 mm

+



950.50.014XA CE

- made of stainless steel, satin finish

OPTIONAL



950.50.01590

- cover for covering fixed mounting plates
- made of synthetic material in HEWI colours 98 (signal white), 99 (pure white)

OPTIONAL



950.50.015XA

- face plate made of high-quality stainless steel, satin finish
- cover frame made of polyamide in HEWI colours 90 (jet black), 92 (anthracite grey), 98 (signal white), 99 (pure white)

Stainless steel CE



950.50.611XA | 600 mm 950.50.621XA | 700 mm
950.50.631XA | 850 mm

+



950.50.01440 CE

- made of stainless steel, chrome-plated

OPTIONAL



950.50.01540

- cover for covering fixed mounting plates
- face plate made of stainless steel, mirror polished
- cover frame made of polyamide in HEWI colour 98 (signal white)

Chrome CE



950.50.61140 | 600 mm 950.50.62140 | 700 mm
950.50.63140 | 850 mm

+

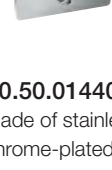

950.50.01440 CE

- made of stainless steel, chrome-plated

OPTIONAL

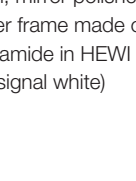

950.50.01540

- cover for covering fixed mounting plates
- face plate made of stainless steel, mirror polished
- cover frame made of polyamide in HEWI colour 98 (signal white)

WARM TOUCH CE



950.50.11150 | 600 mm 950.50.12150 | 700 mm
950.50.13150 | 850 mm

+

OR SET

NECESSARY FOR ALL

OPTIONAL FOR ALL

OR



950.50.10090
 · set of mounting plate 950.50.014XA and cover 950.50.01590

CE

+

BM17.2

For fixing on walls made of concrete (> C20/C25)
 National technical approval number:
 ETA-11/0493

additionally:
 injection mortar (HEWI item No.: 200311)
 or to be provided on site:
 injection mortar HIT-HY200A (Hilti)
 extrusion tool HDM (Hilti)

BM10.2

For fixing on walls made of concrete (> C20/C25)

OR



950.50.100XA
 · set of mounting plate 950.50.014XA and cover 950.50.015XA

CE

+

BM11.2

For fixing on walls made of concrete (> P2)

additionally:
 injection mortar (HEWI item No.: 200266)
 conical drill bit (HEWI item No.: 171041)
 or to be provided on site:
 injection mortar HIT-HY 270 (Hilti)
 extrusion tool HDM (Hilti)
 conical drill bit TE-C PB 22/100 (Hilti)

BM12.2

For fixing on lightweight walls with rear lining made of laminated timber boards (with waterproof bonding, at least 30 mm thick required, e.g. studs or prewall installation)

OR



950.50.10040
 · set of mounting plate 950.50.01440 and cover 950.50.01540

CE

+

BM13.2

For fixing on lightweight walls with integrated steel plates (e.g. studs or pre wall installation)

BM18.2

For fixing on walls made of:
 · solid bricks
 · perforated calcium silicate block
 · hollow concrete block
 · vertically perforated bricks
 · hollow lightweight concrete block
 · lightweight aggregate concrete with open structure

National technical approval number:
 ETA-13/1036

additionally:
 injection mortar (HEWI item No.: 200266)
 or to be provided on site:
 injection mortar HIT-HY 270 (Hilti)
 extrusion tool HDM (Hilti)

OPTIONAL

OPTIONAL

OPTIONAL



Protection and storage bag

950.50.013

· made of high-quality, tearresistant white synthetic material sheeting
 · high-quality fleece lining on the inside to protect the mobile hinged support surfaces