

MOBILE HINGED SEATS

NECESSARY

OPTIONAL
SEPARATELY



900.51.400XA
 · wall bracket made of stainless steel, satin finish
 · seat in HEWI colours 98 (signal white) or 92 (anthracite grey)





900.51.001XA
 · mounting plate made of stainless steel, satin finish

OPTIONAL



900.51.002XA
 · cover for covering fixed mounting plates
 · face plate made of stainless steel, satin finish
 · cover frame made of polyamide in HEWI colours 98 (signal white) or 92 (anthracite grey)



900.51.401XA
 · wall bracket made of stainless steel, satin finish
 · seat in HEWI colours 98 (signal white) or 92 (anthracite grey)



900.51.404XA
 · do., with hygiene cutout





900.51.00140
 · mounting plate made of stainless steel, chrome-plated

OPTIONAL



900.51.00240
 · cover for covering fixed mounting plates
 · face plate made of stainless steel, mirror polished
 · cover frame made of polyamide in HEWI colours 98 (signal white) or 92 (anthracite grey)



900.51.40040
 · wall bracket made of stainless steel, chrome-plated
 · seat in HEWI colours 98 (signal white) or 92 (anthracite grey)





900.51.00160
 · mounting plate made of stainless steel, powder-coated in 3 colours: AS, ER, CV
 · seat in HEWI colours 98 (signal white) or 90 (jet black)

OPTIONAL



900.51.00260
 · cover for covering fixed mounting plates
 · face plate made of stainless steel, powder-coated in AS (matt white) or CV (matt black)
 · cover frame in matching matt white or matt black



900.51.40140
 · wall bracket made of stainless steel, chrome-plated
 · seat in HEWI colours 98 (signal white) or 92 (anthracite grey)



900.51.40440
 · do., with hygiene cutout



900.51.40060
 · wall bracket made of stainless steel, powder-coated in 3 colours: AS, ER, CV
 · seat in HEWI colours 98 (signal white) or 90 (jet black)



900.51.40160
 · wall bracket made of stainless steel, powder-coated in 3 colours: AS, ER, CV
 · seat in HEWI colours 98 (signal white) or 90 (jet black)



900.51.40460
 · do., with hygiene cutout



900.51.40070*
 · wall bracket made of stainless steel, PVD-coated in CK, LP, WR, SV*
 · white seat

900.51.40570* · black seat





900.51.00170*
 · mounting plate made of stainless steel, PVD-coated in CK (brass glossy), LP (brass brushed), WR (nickel brushed), SV (bronze brushed)*



900.51.40170*
 · wall bracket made of stainless steel, PVD-coated in CK, LP, WR, SV*
 · white seat



900.51.40670* · black seat



· do., with hygiene cutout

900.51.40470* · white seat
900.51.40770* · black seat





HEWI Powder coating | Material combinations with synthetic material

-  ...60 AS matt white | white synthetic material
-  ...60 ER matt dark grey pearl mica | black synthetic material
-  ...60 CV matt black | black synthetic material

HEWI Powder coating

-  ...60 DX matt white
-  ...60 SC matt dark grey pearl mica
-  ...60 DC matt black

HEWI PVD-coating | delivery time 4 weeks

-  ...70 CK brass glossy
-  ...70 LP brass brushed
-  ...70 WR nickel brushed
-  ...70 SV bronze brushed

OR SET

NECESSARY FOR ALL

OPTIONAL FOR ALL

OR

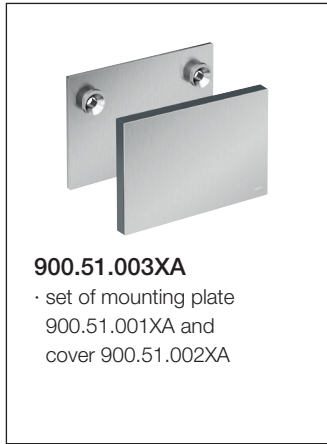

+

BM17.2

For fixing on walls made of concrete (> C20/C25)
National technical approval number: ETA-11/0493

additionally:

injection mortar (HEWI item No.: 200311)

or to be provided on site:

injection mortar HIT-HY200A (Hilti)

extrusion tool HDM (Hilti)

BM10.2

For fixing on walls made of concrete (> C20/C25)

OR

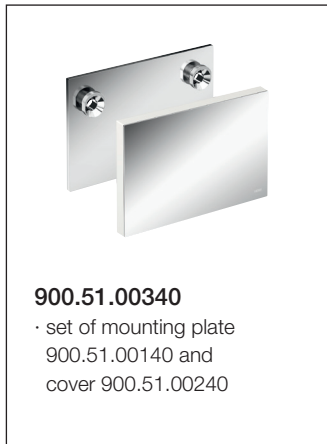

+

BM11.2

For fixing on walls made of autoclaved aerated concrete (> P2)

additionally:

injection mortar (HEWI item No.: 200266)

conical drill bit (HEWI item No.: 171041)

or to be provided on site:

injection mortar HIT-HY 270 (Hilti)

extrusion tool HDM (Hilti)

conical drill bit TE-C PB 22/100 (Hilti)

OR

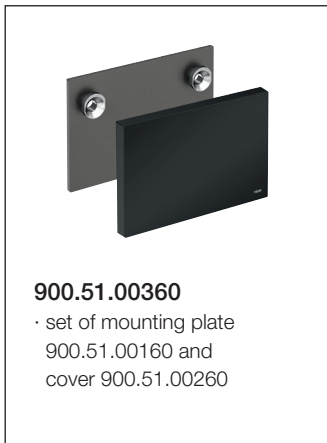

+

BM12.2

For fixing on lightweight walls with rear lining made of laminated timber boards (with waterproof bonding, at least 30 mm thick required, e.g. studs or prewall installation)

BM13.2

For fixing on lightweight walls with integrated steel plates (e.g. studs or pre wall installation)

OR



+

BM18.2

For fixing on walls made of:

- solid bricks
- perforated calcium silicate block
- hollow concrete block
- vertically perforated bricks
- hollow lightweight concrete block
- lightweight aggregate concrete with open structure

National technical approval number: ETA-13/1036

additionally:

injection mortar (HEWI item No.: 200266)

or to be provided on site:

injection mortar HIT-HY 270 (Hilti)

extrusion tool HDM (Hilti)

OPTIONAL

OPTIONAL

OPTIONAL

OPTIONAL



Protection and storage bag

950.51.013

- made of high-quality, tearresistant white synthetic material sheeting
- high-quality fleece lining on the inside to protect the seat surfaces

* HEWI PVD-coating | delivery time 12 weeks

- ...70 UN bronze glossy
- ...70 DP copper glossy
- ...70 RB copper brushed

- ...70 BZ gold glossy
- ...70 VT gold brushed
- ...70 JL nickel glossy