

MOBILE HINGED SUPPORT RAILS

NECESSARY

OPTIONAL  
SEPARATELY

**Polyamide, single-coloured** CE



950.50.11190 | 600 mm



950.50.12190 | 700 mm  
950.50.13190 | 850 mm

**Polyamide, two-coloured** CE



950.50.11191 | 600 mm  
950.50.11199 | 600 mm



950.50.12191 | 700 mm  
950.50.12199 | 700 mm  
950.50.13191 | 850 mm  
950.50.13199 | 850 mm

+



**950.50.014XA**  
· made of stainless steel,  
satin finish

OPTIONAL



**950.50.01590**  
· cover for covering fixed  
mounting plates  
· made of synthetic material  
in HEWI colours 98 (signal  
white) or 99 (pure white)

**Chrome** CE

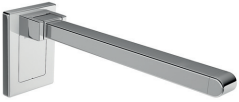

950.50.61140 | 600 mm



950.50.62140 | 700 mm  
950.50.63140 | 850 mm

+



**950.50.01440**  
· made of stainless steel,  
chrome-plated

OPTIONAL



**950.50.01540**  
· cover for covering fixed  
mounting plates  
· face plate made of stainless  
steel, mirror polished  
· cover frame made of  
polyamide in HEWI colour  
98 (signal white)

**WARM TOUCH** CE



950.50.11150 | 600 mm



950.50.12150 | 700 mm  
950.50.13150 | 850 mm

+

**OR SET**

**NECESSARY FOR ALL**

**OPTIONAL**

OR



**950.50.10090**  
 · set of mounting plate 950.50.0144XA and cover 950.50.01590

+

OR

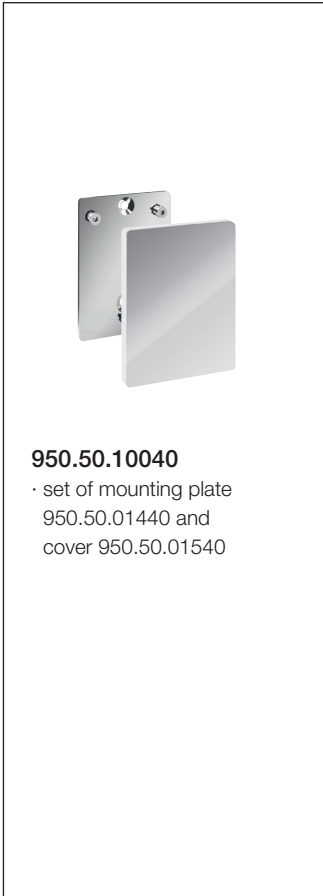

**950.50.10040**  
 · set of mounting plate 950.50.01440 and cover 950.50.01540

+

**BM17.2**

For fixing on walls made of concrete (> C20/C25)  
 National technical approval number: ETA-11/0493

additionally:

injection mortar (HEWI item No.: 200311)

or to be provided on site:

injection mortar HIT-HY200A (Hilti)

extrusion tool HDM (Hilti)

**BM10.2**

For fixing on walls made of concrete (> C20/C25)

**BM11.2**

For fixing on walls made of autoclaved aerated concrete (> P2)

additionally:

injection mortar (HEWI item No.: 200266)

conical drill bit (HEWI item No.: 171041)

or to be provided on site:

injection mortar HIT-HY 270 (Hilti)

extrusion tool HDM (Hilti)

conical drill bit TE-C PB 22/100 (Hilti)

**BM12.2**

For fixing on lightweight walls with rear lining made of laminated timber boards (with waterproof bonding, at least 30 mm thick required, e.g. studs or prewall installation)

**BM13.2**

For fixing on lightweight walls with integrated steel plates (e.g. studs or pre wall installation)

**BM18.2**

For fixing on walls made of:

- solid bricks
- perforated calcium silicate block
- hollow concrete block
- vertically perforated bricks
- hollow lightweight concrete block
- lightweight aggregate concrete with open structure

National technical approval number: ETA-13/1036

additionally:

injection mortar (HEWI item No.: 200266)

or to be provided on site:

injection mortar HIT-HY 270 (Hilti)

extrusion tool HDM (Hilti)

**UPGRADE PRODUCTS**

**for polyamide**

**950.50.01090**

· upgrade kit toilet roll holder

**950.50.07090** right

**950.50.07190** left

· upgrade kit WC flushing mechanism (radio-controlled)

**950.50.020XA**

**950.50.025XA**

**950.50.026XA**

· floor support

**for chrome**

**950.50.01150**

· upgrade kit toilet roll holder

**950.50.07290** right

**950.50.07390** left

· upgrade kit WC flushing mechanism (radio-controlled)

**950.50.020XA,**

**950.50.025XA**

**950.50.026XA**

· floor support

**for WARM TOUCH**

**950.50.01050**

· upgrade kit toilet roll holder

**950.50.07090** right

**950.50.07190** left

· upgrade kit WC flushing mechanism (radio-controlled)

**950.50.020XA**

**950.50.025XA**

**950.50.026XA**

· floor support

**OPTIONAL FOR ALL**

**Protection and storage bag**

**950.50.013**

· made of high-quality, tearresistant white synthetic material sheeting  
 · high-quality fleece lining on the inside to protect the mobile hinged support surfaces

OPTIONAL

OPTIONAL

OPTIONAL