



MOBILE HINGED SEATS

NECESSARY

OPTIONAL
SEPARATELY



900.51.400XA
 · wall bracket made of stainless steel, satin finish
 · seat made of thermoplastic synthetic material in HEWI colours 98 (signal white) or 92 (anthracite grey)



900.51.401XA
 · wall bracket made of stainless steel, satin finish
 · seat made of thermoplastic synthetic material in HEWI colours 98 (signal white) or 92 (anthracite grey)



900.51.404XA
 · wall bracket made of stainless steel, satin finish
 · seat made of thermoplastic synthetic material in HEWI colours 98 (signal white) or 92 (anthracite grey)



900.51.40040
 · wall bracket made of stainless steel, chrome-plated
 · seat made of thermoplastic synthetic material in HEWI colours 98 (signal white) or 92 (anthracite grey)



900.51.40140
 · wall bracket made of stainless steel, chrome-plated
 · seat made of thermoplastic synthetic material in HEWI colours 98 (signal white) or 92 (anthracite grey)



900.51.40440
 · wall bracket made of stainless steel, chrome-plated
 · seat made of thermoplastic synthetic material in HEWI colours 98 (signal white) or 92 (anthracite grey)



900.51.40060
 · wall bracket made of stainless steel, powder-coated in 3 colours: AS, ER, CV
 · seat made of thermoplastic synthetic material in HEWI colours 98 (signal white) or 90 (jet black)



900.51.40160
 · wall bracket made of stainless steel, powder-coated in 3 colours: AS, ER, CV
 · seat made of thermoplastic synthetic material in HEWI colours 98 (signal white) or 90 (jet black)



900.51.40460
 · wall bracket made of stainless steel, powder-coated in 3 colours: AS, ER, CV
 · seat made of thermoplastic synthetic material in HEWI colours 98 (signal white) or 90 (jet black)

+

+

+



900.51.001XA
 · mounting plate made of stainless steel, satin finish



900.51.00140
 · mounting plate made of stainless steel, chrome-plated



900.51.00160
 · mounting plate made of stainless steel, powder-coated in 3 colours: DX (matt white), SC (matt dark grey pearl mica) or DC (matt black)

OPTIONAL

OPTIONAL

OPTIONAL



900.51.002XA
 · cover for covering fixed mounting plates
 · face plate made of stainless steel, satin finish
 · cover frame made of polyamide in HEWI colours 98 (signal white) or 92 (anthracite grey)





900.51.00240
 · cover for covering fixed mounting plates
 · face plate made of stainless steel, mirror polished
 · cover frame made of polyamide in HEWI colours 98 (signal white) or 92 (anthracite grey)



900.51.00260
 · cover for covering fixed mounting plates
 · face plate made of stainless steel, powder-coated in AS (matt white) or CV (matt black)
 · cover frame in matching matt white or matt black

HEWI Powder coating | Material combinations with synthetic material

-  ...60 AS matt white | white synthetic material
-  ...60 ER matt dark grey pearl mica | black synthetic material
-  ...60 CV matt black | black synthetic material

HEWI Powder coating

-  ...60 DX matt white
-  ...60 SC matt dark grey pearl mica
-  ...60 DC matt black

OR SET

NECESSARY FOR ALL

OPTIONAL FOR ALL

OR



+

BM17.2

For fixing on walls made of concrete (> C20/C25)
National technical approval number:
ETA-11/0493

additionally:
injection mortar (HEWI item No.: 200311)
or to be provided on site:
injection mortar HIT-HY200A (Hilti)
extrusion tool HDM (Hilti)

BM10.2

For fixing on walls made of concrete (> C20/C25)

BM11.2

For fixing on walls made of concrete (> P2)

additionally:
injection mortar (HEWI item No.: 200266)
conical drill bit (HEWI item No.: 171041)
or to be provided on site:
injection mortar HIT-HY 270 (Hilti)
extrusion tool HDM (Hilti)
conical drill bit TE-C PB 22/100 (Hilti)

+

BM12.2

For fixing on lightweight walls with rear lining made of laminated timber boards (with waterproof bonding, at least 30 mm thick required, e.g. studs or prewall installation)

BM13.2

For fixing on lightweight walls with integrated steel plates (e.g. studs or pre wall installation)

BM18.2

For fixing on walls made of:

- solid bricks
- perforated calcium silicate block
- hollow concrete block
- vertically perforated bricks
- hollow lightweight concrete block
- lightweight aggregate concrete with open structure

National technical approval number:
ETA-13/1036

additionally:
injection mortar (HEWI item No.: 200266)
or to be provided on site:
injection mortar HIT-HY 270 (Hilti)
extrusion tool HDM (Hilti)

+

OR

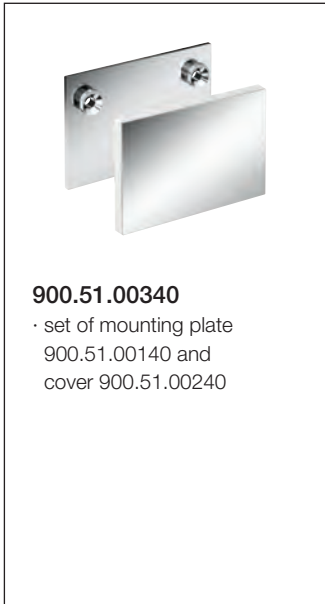

OR



OPTIONAL

OPTIONAL

OPTIONAL



Protection and storage bag

950.51.013

- made of high-quality, tearresistant white synthetic material sheeting
- high-quality fleece lining on the inside to protect the seat surfaces