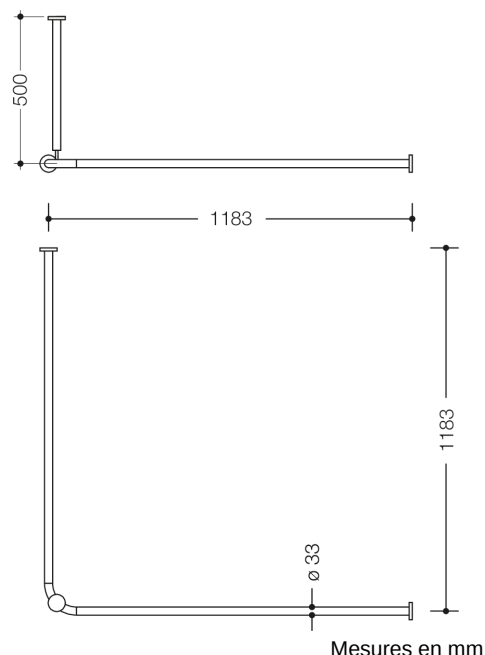



Photo similaire



Mesures en mm

### Propriétés

Tringle à rideaux avec suspension pour le plafond de la Série 801

- barres verticales et horizontales assemblées en angle droit avec anneaux à rideaux
- sert à fixer un rideau de douche
- montage au mur et au plafond avec le matériel de fixation anti-corrosion HEWI et des rosaces
- tringle à rideaux pour baignoire 1200 x 1200 mm, dimension de l'entraxe 1183 x 1183 mm, peut être raccourcie jusqu'à 220 mm aux extrémités
- suspension pour le plafond 500 mm de long, longueur réglable de 10 mm et raccourcissable de max. 100 mm au niveau de la rosace
- diamètre de tringle 33 mm
- avec 24 anneaux pour rideau
- en polyamide de haute qualité, par selon nuancier HEWI
- avec cœur en aluminium

### Awards



### Couleurs / Surfaces

 33 (rouge rubis)	 74 (vert pomme)	 92 (gris anthracite)	 99 (blanc pur)
 36 (corail)	 18 (jaune moutarde)	 95 (gris souris)	 84 (umbra)
 50 (bleu acier)	 86 (sable)	 97 (gris clair)	
 55 (bleu aqua)	 90 (noir foncé)	 98 (blanc signalis.)	

Sous réserve de toutes modifications techniques, 24.12.2023