

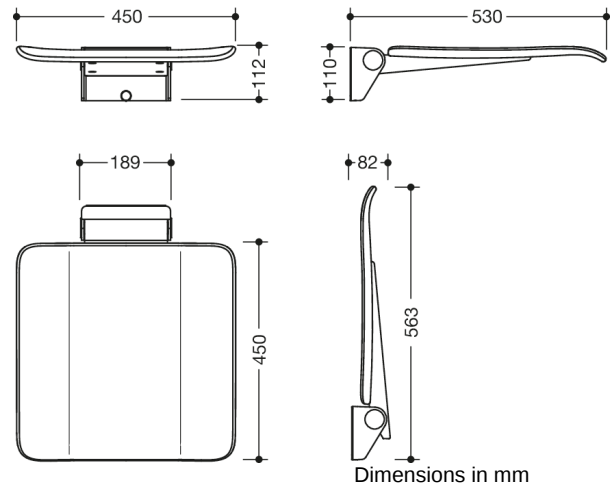

Similar picture



Properties

Mobile hinged seat, System 900

- construction consisting of wall bracket and continuous seat
- slip-resistant, textured seat made of synthetic material in HEWI colours 98 (signal white) and 92 (anthracite grey)
- reinforcement of the seat made of aluminium, powder coated in the colour of the seat
- wall bracket made of stainless steel, chrome
- seat can be folded up to save space
- seat depth when folded up 77 mm
- weight capacity up to 150 kg
- for mobile use
- for easy and flexible retrofitting on existing, preassembled mounting plate 900.51.00140 (must be ordered separately)
- tool-free and quick installation by means of simple hanging of the seat
- secured by fixing screw
- 450 mm wide, 530 mm deep and 112 mm high
- seat 450 mm wide and 450 mm deep
- for mounting with non-corrosive and tested HEWI fixing materials for different wall systems (to be ordered separately)
- sealing tape and sealing discs for sealing the fixing points according to DIN 18534 are included in the scope of delivery
- fulfils the DIN 18040, ÖNORM B1600/1601 and SIA 500 requirements

Awards



Colours / Surfaces

- 98 (signal white)
- 92 (anthracite grey)