

BACKREST RAIL

MOBILE HINGED SUPPORT RAILS

NECESSARY

Polyamide



950.51.90090

- c to c 650-700 mm adjustable on site
- 150 mm deep
- backrest made of glass fibre reinforced polyamide in HEWI colours 98 (signal white) and 92 (anthracite grey)
- mounting bar made of metal, white powder-coated

Polyamide CE

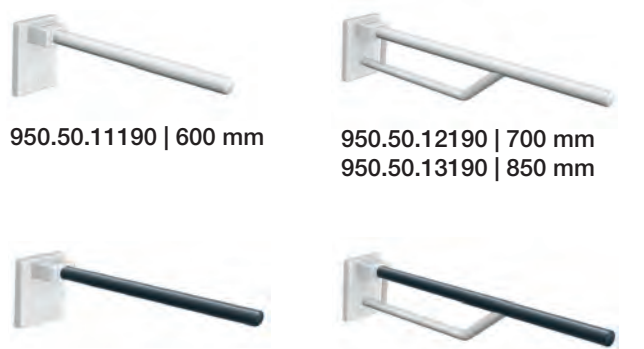

950.50.11190 | 600 mm 950.50.12190 | 700 mm
950.50.13190 | 850 mm



950.50.11191 | 600 mm 950.50.12191 | 700 mm
950.50.11199 | 600 mm 950.50.12199 | 700 mm
950.50.13191 | 850 mm 950.50.13199 | 850 mm

Stainless steel CE



950.50.611XA | 600 mm 950.50.621XA | 700 mm
950.50.631XA | 850 mm

Chrome CE



950.50.61140 | 600 mm 950.50.62140 | 700 mm
950.50.63140 | 850 mm

WARM TOUCH CE



950.50.11150 | 600 mm 950.50.12150 | 700 mm
950.50.13150 | 850 mm



950.50.014XA

- made of stainless steel, satin finish



950.50.01440

- made of stainless steel, chrome-plated

Backrest rail can also be combined with stationary hinged support rails.

**OPTIONAL
SEPARATELY OR SET**

NECESSARY FOR ALL

OPTIONAL



950.50.01590

- cover for covering fixed mounting plates
- made of synthetic material in HEWI colours 98 (signal white), 99 (pure white)

OR



950.50.10090

- set of mounting plate 950.50.014XA and cover 950.50.01590

CE

+

BM17.2

For fixing on walls made of concrete (> C20/C25)
National technical approval number:
ETA-11/0493

additionally:
injection mortar (HEWI item No.: 200311)
or to be provided on site:
injection mortar HIT-HY200A (Hilti)
extrusion tool HDM (Hilti)

BM10.2

For fixing on walls made of concrete (> C20/C25)

BM11.2

For fixing on walls made of concrete (> P2)

additionally:
injection mortar (HEWI item No.: 200266)
conical drill bit (HEWI item No.: 171041)
or to be provided on site:
injection mortar HIT-HY 270 (Hilti)
extrusion tool HDM (Hilti)
conical drill bit TE-C PB 22/100 (Hilti)

OPTIONAL



950.50.015XA

- face plate made of high-quality stainless steel, satin finish
- cover frame made of polyamide in HEWI colours 90 (jet black), 92 (anthracite grey), 98 (signal white), 99 (pure white)

OR



950.50.100XA

- set of mounting plate 950.50.014XA and cover 950.50.015XA

CE

+

BM12.2

For fixing on lightweight walls with rear lining made of laminated timber boards (with waterproof bonding, at least 30 mm thick required, e.g. studs or prewall installation)

BM13.2

For fixing on lightweight walls with integrated steel plates (e.g. studs or pre wall installation)

OPTIONAL



950.50.01540

- cover for covering fixed mounting plates
- face plate made of stainless steel, mirror polished
- cover frame made of polyamide in HEWI colour 98 (signal white)

OR



950.50.10040

- set of mounting plate 950.50.01440 and cover 950.50.01540

CE

+

BM18.2

For fixing on walls made of:

- solid bricks
- perforated calcium silicate block
- hollow concrete block
- vertically perforated bricks
- hollow lightweight concrete block
- lightweight aggregate concrete with open structure

National technical approval number:
ETA-13/1036

additionally:
injection mortar (HEWI item No.: 200266)
or to be provided on site:
injection mortar HIT-HY 270 (Hilti)
extrusion tool HDM (Hilti)