

D Montageanleitung

GB Installation instructions

Montagevorbereitung Vollblatztür
Mounting preparations S. 4

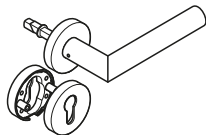

Montage Vollblatztür
Mounting full leaf door S. 6

Demontage Vollblatztür
Demounting full leaf door S. 7

Montagevorbereitung Rohrrahmentür
Mounting preparations tubular frame door S. 8

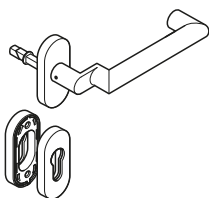

Montage Rohrrahmentür
Mounting tubular frame door S. 9

Demontage Rohrrahmentür
Demounting tubular frame door S. 10

Entriegelung Rohrrahmentür
Unlocking tubular frame door S. 11

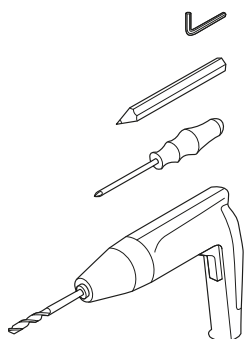

Werkzeuge zur Montage
Tools for mounting

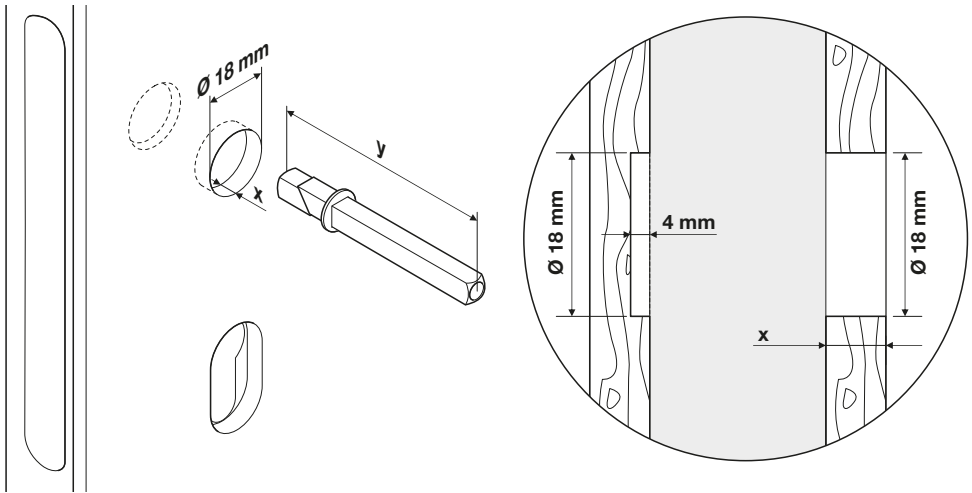

x	y
9 - 19	58
14 - 29	68
29 - 39	78
39 - 49	88
49 - 59	98
59 - 69	108

Montagevorbereitung Vollblattdür
Mounting preparation full leaf door

a

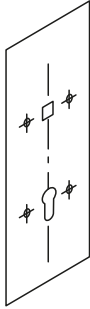

a1

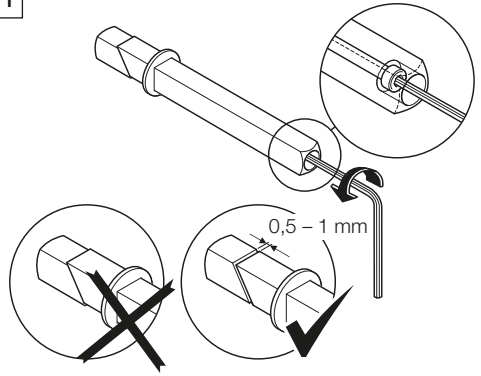

a2

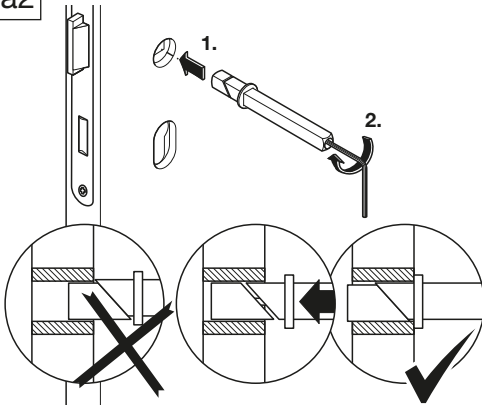

a3

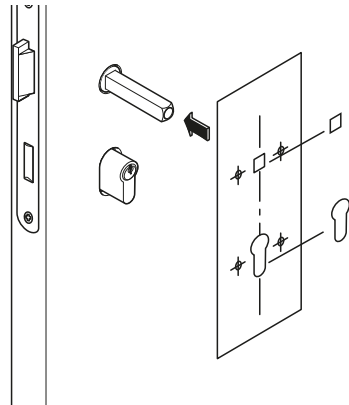

a4

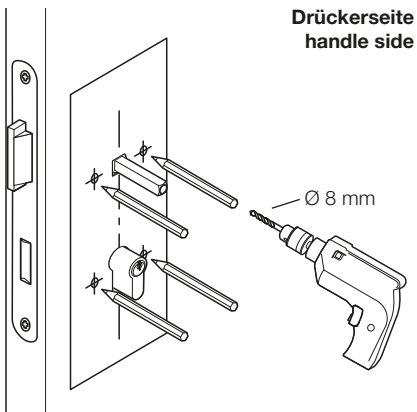

a5

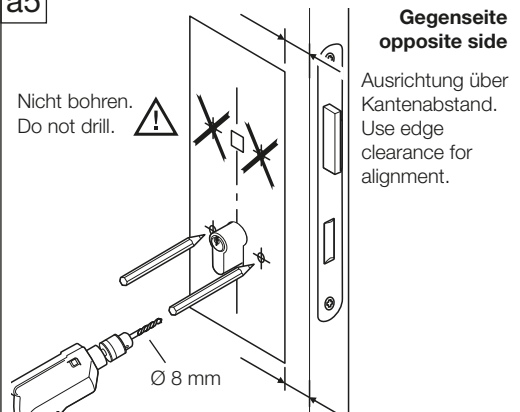

b

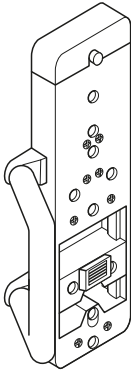

b1

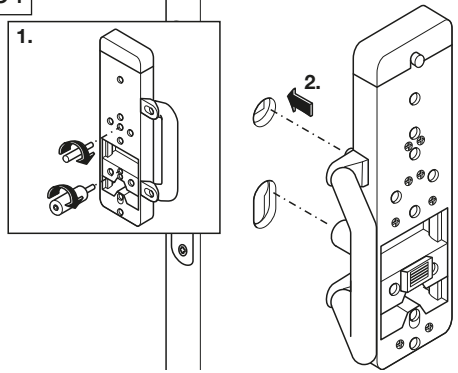

b2

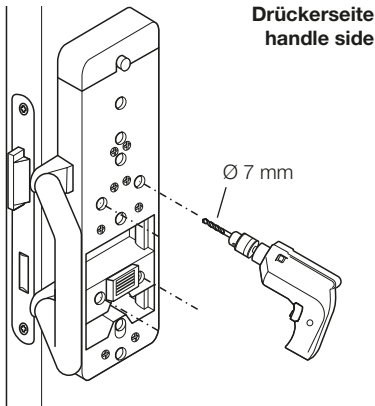

b3

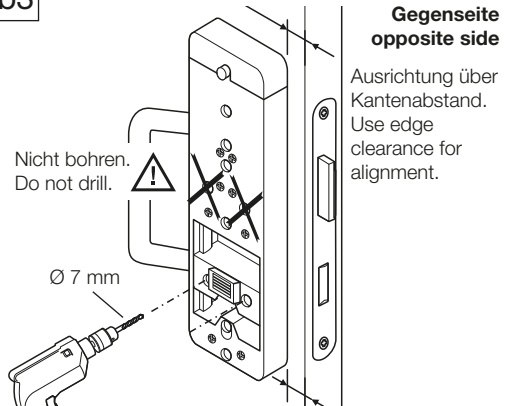

b4

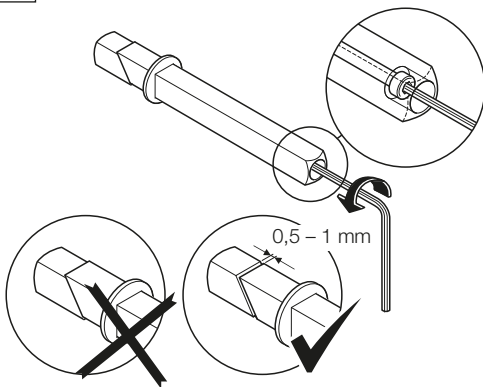

b5

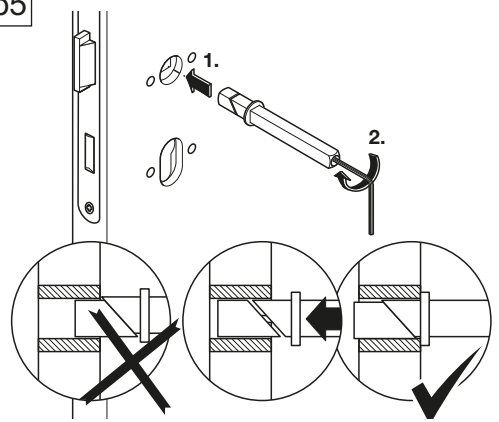

Montage Vollblattdür
Mounting full leaf door

1

F FS-Türen: Stahlrosetten
 F-doors: steel rose

Anzugsmoment | clamping torque = $M < 2 \text{ Nm}$

2

3

CLICK!

4

Test

5

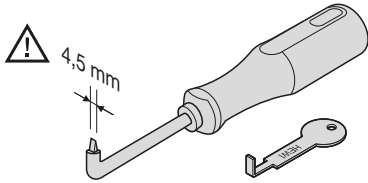

1

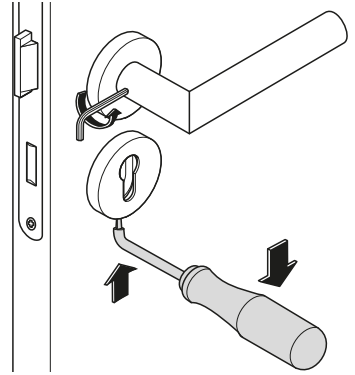

2

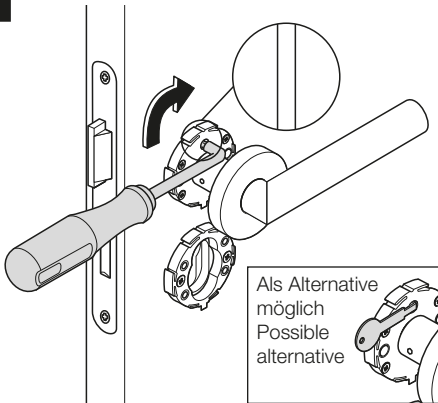

3

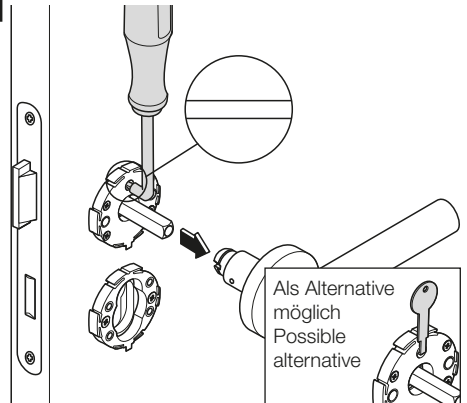

4

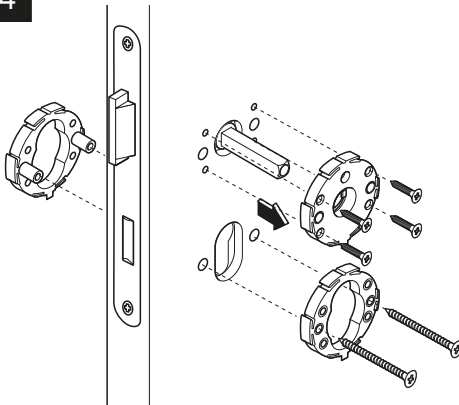

5

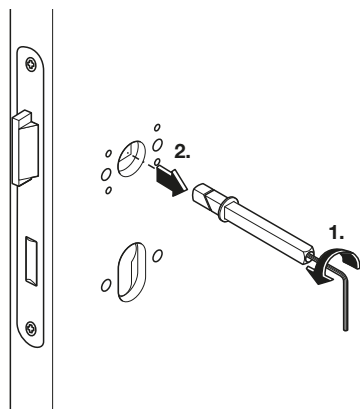

Montagevorbereitung Rohrrahmentür
Mounting preparation tubular frame door

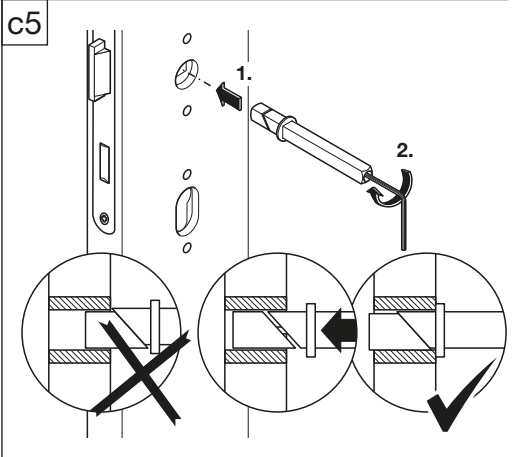
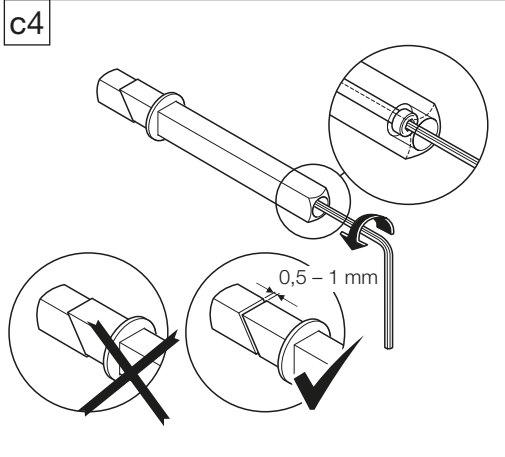
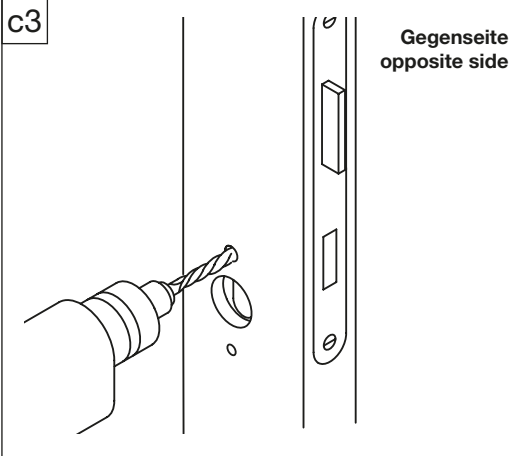
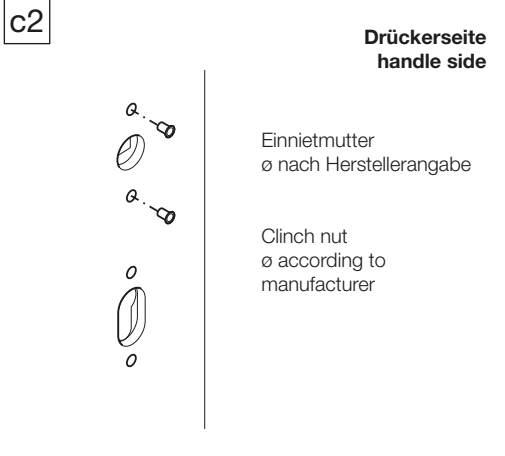
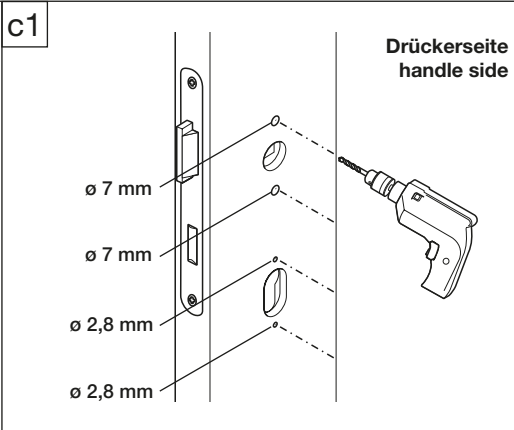
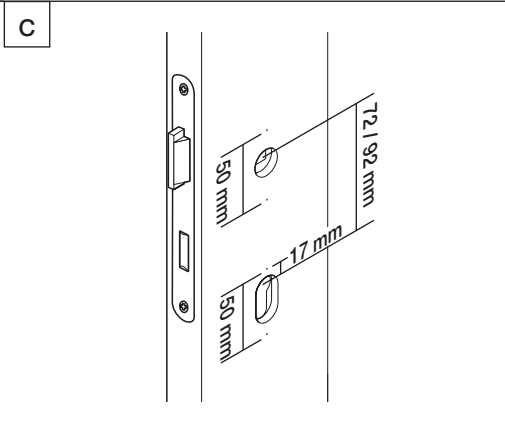

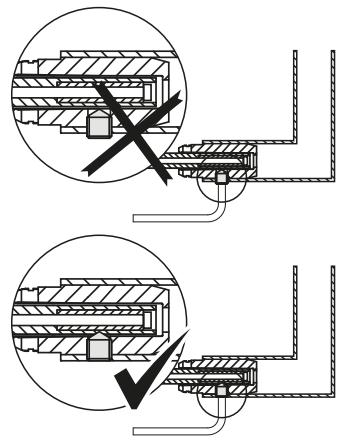
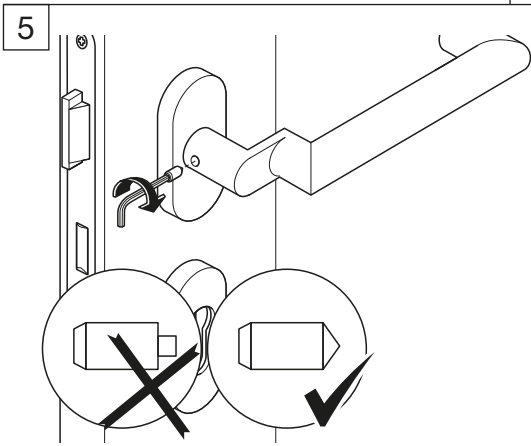
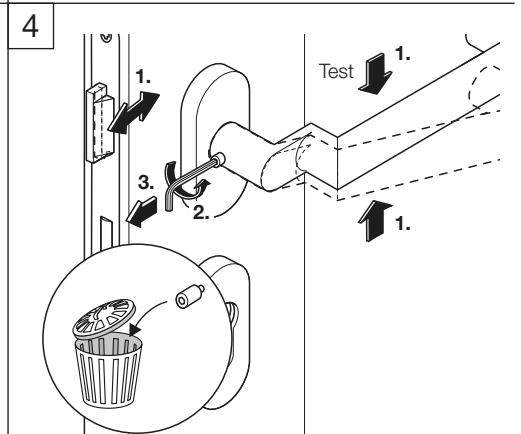
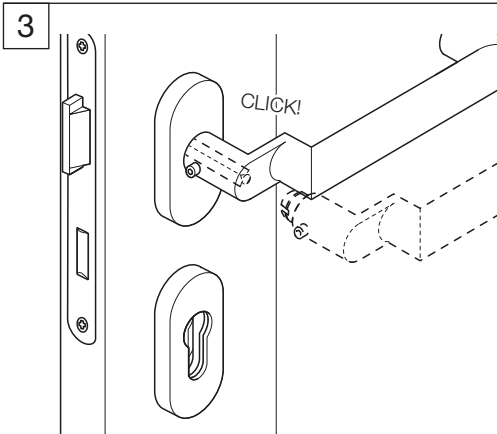
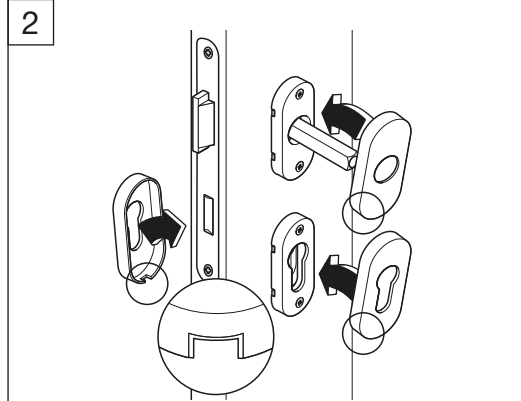
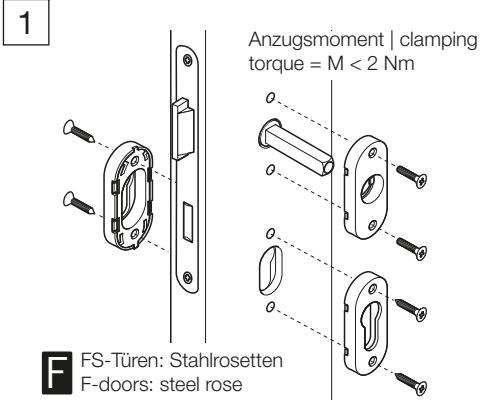

Demontage Rohrrahmentür
Demounting tubular frame door

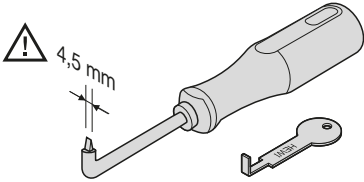

1

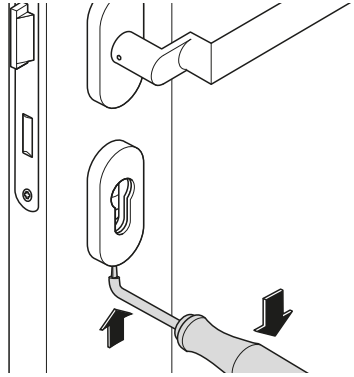

2

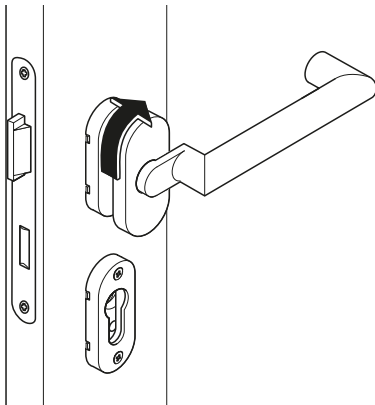

3

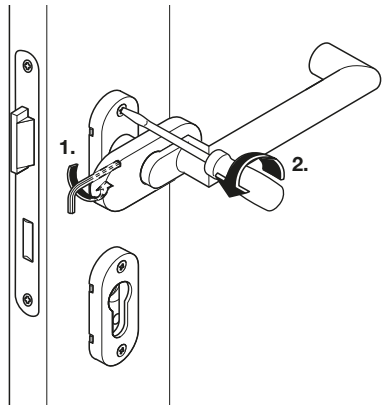

4

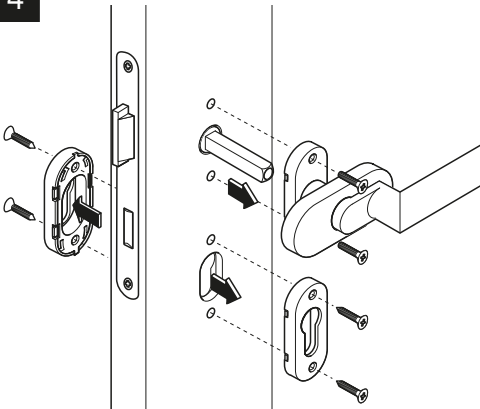

5

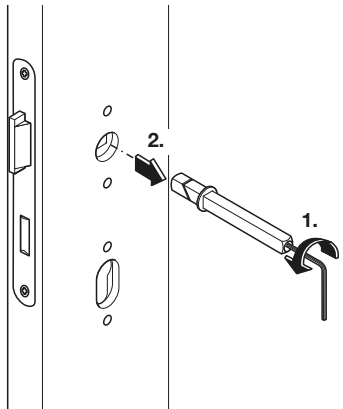

a

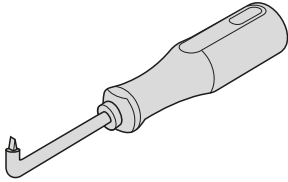

b



a1

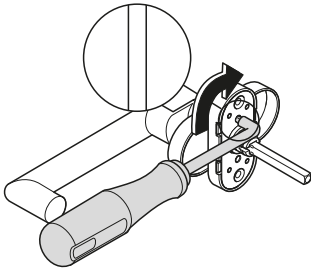

b1

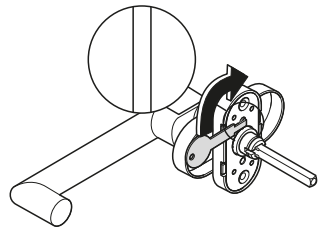

a2

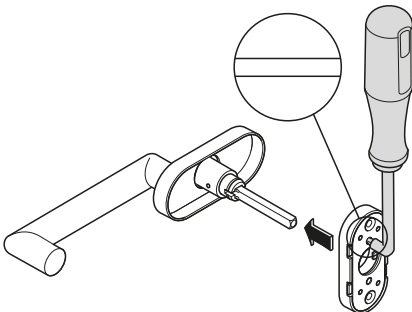

b2

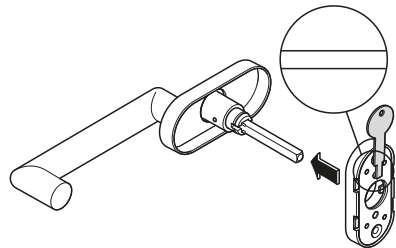

HEWI

www.hewi.com

Deutschland

HEWI Heinrich Wilke GmbH

Postfach 1260

D-34442 Bad Arolsen

Telefon: +49 5691 82-0

Telefax: +49 5691 82-319

info@hewi.de