

S 50 Height-Adjustable Modules Planning & Design Information



HEWI Planning & Design and Advice

We would be pleased to advise you in person. Please contact our support team, if you have further questions about your planning & design. You can reach the HEWI support team on:

Monday to Thursday

07:00 – 17:00

Friday

07:00 – 15:00

Phone: +49 5691 82-0

Fax: +49 5691 82-493

Email: international@hewi.com

Up-to-dateness of the information

HEWI products are subject to a continuous improvement process. We therefore reserve the right to make changes without notice in line with technical progress.

You will find the latest version of the planning & design information in the online catalogue under S 50 and under www.hewi.de/brochures on our website.

Dated 04/2023

Content

04 Product Description

- 05 Functional Aspects
- 06 Modules Overview
- 10 Structural Principle
- 12 Product Dimensions

14 Spatial Installation Requirements

- 14 Positioning of the Drain
- 16 Positioning of the Water Connection
- 18 Positioning of the Power Connection
- 20 Notes on the Power Connection in the Bathroom
- 22 Installation | Wall Quality
- 24 Floor-ceiling installation
- 26 Installation | Floor
- 28 Required Clearances
- 30 Required Distance from the Wall
- 32 Dry Lining | Drywall Requirements
- 33 Maximum Thickness of the Wall build-up
- 34 Integration in Studwork Elements
- 36 Minimum Spacing of Row Installations

38 Inspection

- 38 Positions of the Inspection Openings

40 Accessories

- 41 Hinged Support Rails Add-On Kit | Range 802 LifeSystem
- 42 Hinged Support Rails Add-On Kit | System 100 and 800
- 43 Hinged Support Rails Add-On Kit | System 800 K | WARM TOUCH
- 44 Hinged Support Rails Add-On Kit | Range 805 Classic | Range 801 | System 900 design B
- 45 Backrest Rails | Range 805 Classic | Range 801
- 46 Hinged Support Rails Add-On Kit | System 900 design A
- 47 Backrest Rails | Range 805 Classic | System 900 design A





Functional Aspects

COMPACT DESIGN

The height-adjustable washbasin and toilet modules have a convincingly compact design. The distance from the wall to the front element (fitout module) is 25 mm. The modules are available with fronts made of Plexiglas in white.

HYGIENE

Functional elements, such as a mirror and flushing panel, are recessed flush with the surface and are thus easy to clean. The high-quality fronts made of Evonik Plexiglas are not susceptible to scratches. The smooth, dirt-repelling surface is easy to clean. The all-round dust brush strip forms the finish with the wall and thus increases hygiene effectively.

LOW NOISE

The modules are driven by a motor, which is extremely low-noise. All pipes, cables and the installation element are sound-insulated from the structure and fulfil the requirements of DIN 4109, ÖNORM B 8115 and SIA 181 (see page 32).

FIRE PROTECTION

The front made of Plexiglas and the HPL mounting panel underneath it fulfil the fire protection B2 requirements in accordance with DIN 4102.

Washbasin Module

The washbasin module can be continually adjusted by up to 300 mm using the radio remote control. The initial position of the module can be raised additionally by up to 200 mm during installation (see pages 26-27). The entire module moves, so that the mirror is not concealed by the washbasin.

WASHBASIN

Selected HEWI washbasins (in the scope of supply) can be combined with S 50 (see below). The particularly shallow basin of the mineral composite washbasin combined with an in-wall trap allows it to be used in a seated position.

ILLUMINATED MIRROR

The washbasin module is optionally available with an energy efficient LED mirror (see page 8). An additional radio remote control can be used to dim the light and set the light temperature.

TECHNICAL DATA

Stroke height: 300 mm
 Voltage: 230 V (50/60Hz)
 Water connection: 1/2"
 Loading capacity up to 150 kg

NOTES ON INSTALLATION

Wall build-up: min.12,5 mm/max. 35 mm
 Installation depth: 210-240 mm



950.11.161
650 x 130 x 550 mm



950.13.201
650 x 140 x 550 mm



M40.11.501
650 x 125 x 550 mm



950.11.101
600 x 100 x 550 mm



950.11.121
600 x 100 x 550 mm

Toilet Module

The toilet module can be continuously adjusted by up to 150 mm vertically using a radio remote control. This is also possible during use, so that the module serves as a convenient sitting and standing up aid. The initial position of the toilet can be changed by up to 200 mm during installation (for example from the standard height of 420-425 mm to an accessible height of 460-480 mm).

FLUSHING MECHANISM

The toilet module is optionally available with manual or sensor-controlled flushing mechanism (see page 9).

HINGED SUPPORT RAILS

The toilet module can be optionally fitted with HEWI hinged support rails (see pages 41-47). The hinged support rails move with the toilet module.

TOILETS AND WASHLETS

All conventional toilets can be used with the toilet module, if they have a fixing distance of 180 or 230 mm and are not longer than 700 mm.

The following shower toilets and washlets can be combined with the toilet module:

- Axent One shower toilet | One plus
- Duravit SensoWash e shower-toilet seat
- Duravit SensoWash Slim shower-toilet seat
- Geberit AquaClean shower toilets: Alba | Mera | Sela | Tuma
- Grohe Sensia Arena shower toilet
- LaPreva LaPreva P2 combined toilet bidet
- Laufen Cleanet Riva shower toilet
- Laufen Cleanet Navia shower toilet
- Toto Washlet EK 2.0 (requires Geberit AquaClean Y-branch 3/8", to be provided on site)
- Toto Washlet GL 2.0 (requires Geberit AquaClean Y-branch 3/8", to be provided on site)
- Toto Washlet RX (requires Geberit AquaClean Y-branch 3/8", to be provided on site)

TECHNICAL DATA

Stroke height: 150 mm
 Adjustable seat height: approx. 425-575 mm
 Voltage: 230 V (50/60Hz)
 Water connection: 1/2"
 Max. user weight 150 kg
 Dual flush cistern, flushing quantity: factory setting
 6/3 litres (adjustable to 4/2 litres or 7/3 litres)

NOTES ON INSTALLATION

Wall build-up: min. 12,5 mm / max. 35 mm
 Installation depth: 210-240 mm
 Ceramic requirement: toilet max. 700 mm long





S50.01.202010
Washbasin module with
washbasin 950.11.101



S50.01.302010
Washbasin module with
washbasin M40.11.501



S50.01.702010
Washbasin module with
washbasin 950.11.161



S50.01.902010
Washbasin module with
washbasin 950.13.201

S50.01.502010
Washbasin module with
washbasin 950.11.121



S50.01.212010
Washbasin module with
illuminated mirror and
washbasin 950.11.101



S50.01.312010
Washbasin module with
illuminated mirror and
washbasin M40.11.501



S50.01.712010
Washbasin module with
illuminated mirror and
washbasin 950.11.161



S50.01.912010
Washbasin module with
illuminated mirror and
washbasin 950.13.201

S50.01.512010
Washbasin module with
illuminated mirror and
washbasin 950.11.121



S50.02.102010
Toilet module with
manual flushing panel



S50.02.112010
Toilet module with
sensor-controlled flushing
mechanism



S50.02.0001...
Hinged support rail add-on kit
for range 801, 805 Classic,
system 900 design B



S50.02.00021
Hinged support rail add-on kit
for range/system 100, 800,
800 K, WARM TOUCH



S50.02.0003...
Hinged support rail add-on
kit for range 802 LifeSystem



S50.02.0004...
Hinged support rail add-on
kit for system 900 design A

Washbasin Module Structural Principle

The washbasin module is specified as a complete system and is delivered in two phases (shell and core and finishing phase) in line with the construction schedule.

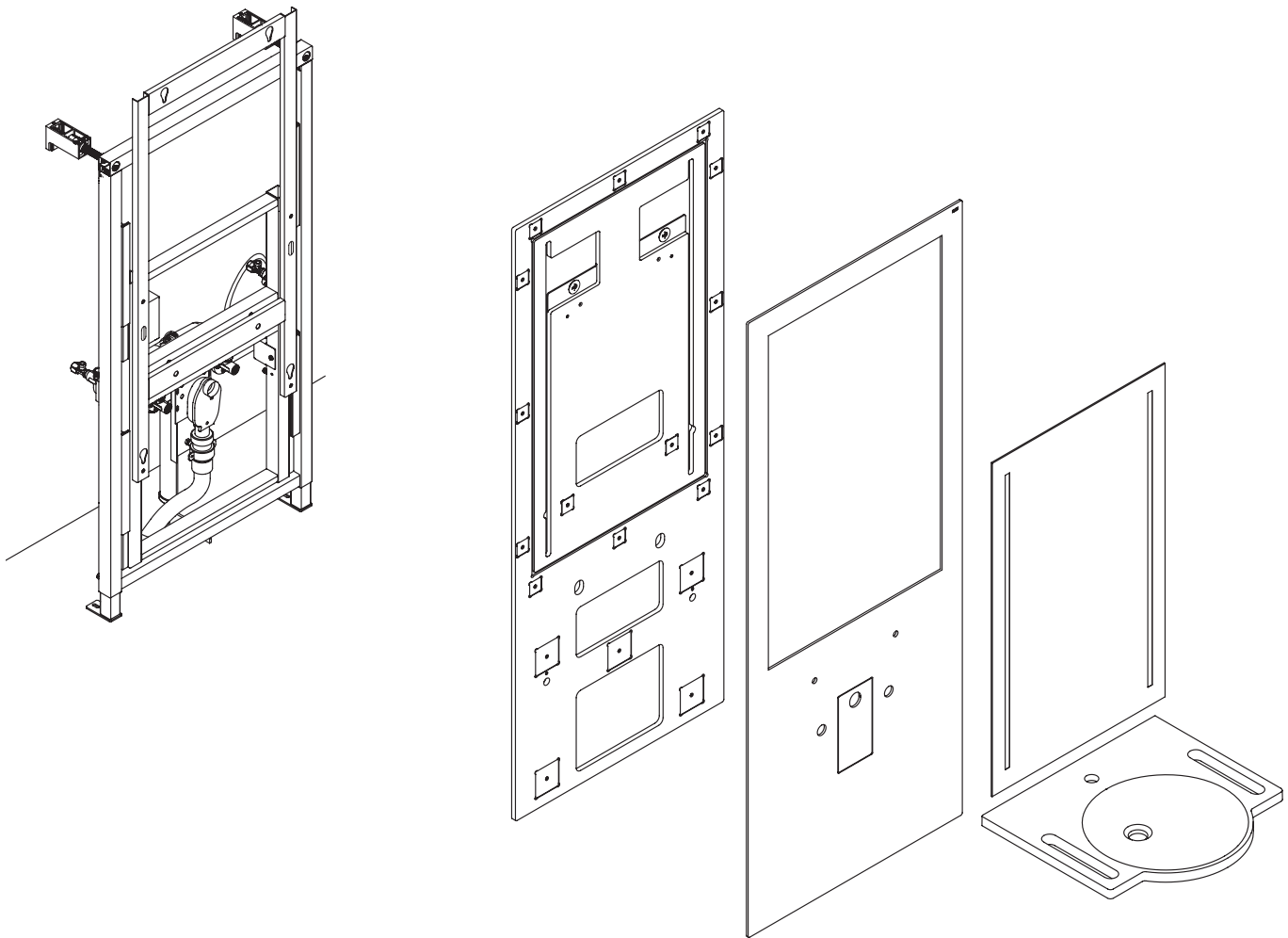

HPL mounting panel

Plexiglas front

Mirror and washbasin

**1. Shell and core
construction phase:
Prewall element**

**2. Finishing phase:
Fitout element**

To be provided on site:

- 2 water connections ½" for water supply (hot and cold water)
- 2 flexible hoses (connection height 650 mm)
- Power connection (230 V)
- If applicable, wastewater pipe extension DN 40

To be provided on site:

- Monobloc (single hole) mixer tap incl. 2 supply hoses (hot and cold water)
- 2 corner valves ½", extension if required

Recommendation:

- 2 Hansgrohe corner valve S (Art. No. 13901000)
- 2 Viega extension/threaded fitting ½" x 100 mm (Art. No. 357245)

Toilet Module Structural Principle

The toilet module is specified as a complete system and is delivered in two phases (shell and core and finishings phase) in line with the construction schedule.

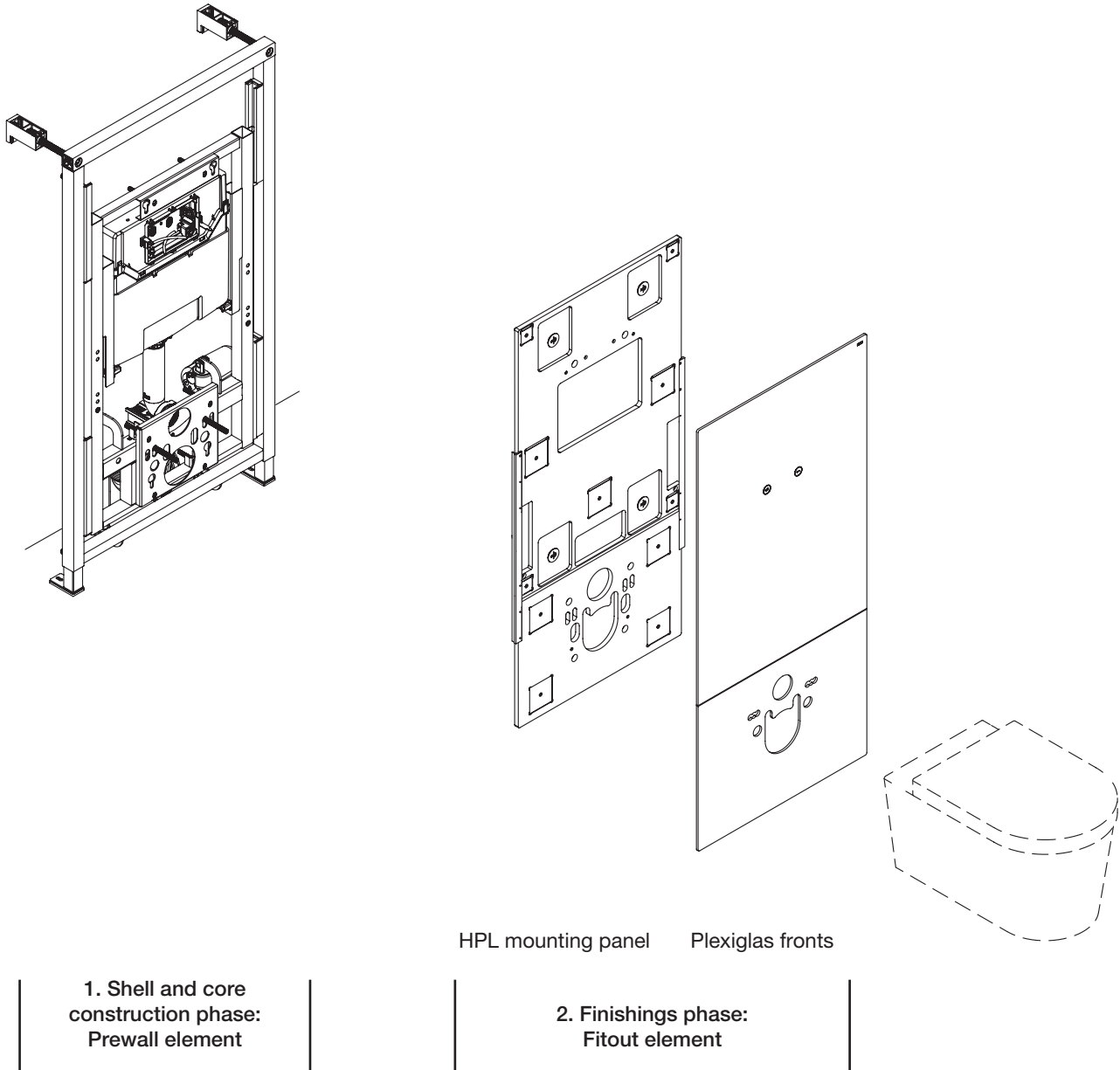

**1. Shell and core
construction phase:
Prewall element**

HPL mounting panel Plexiglas fronts

**2. Finishings phase:
Fitout element**

To be provided on site:

- Power connection (230 V)
- Water connection 1/2" for the cistern
- Flexible hose 1/2" for connection of the cistern (allow for 150 mm adjustment movement of the toilet in the length of the hose)
- Floor gully \varnothing 90 mm (for positioning see page 15) or side outlet (maximum distance to the riser 4 m)

To be provided on site:

- Toilet ceramics incl. sound insulation kit

Washbasin Module Product Dimensions

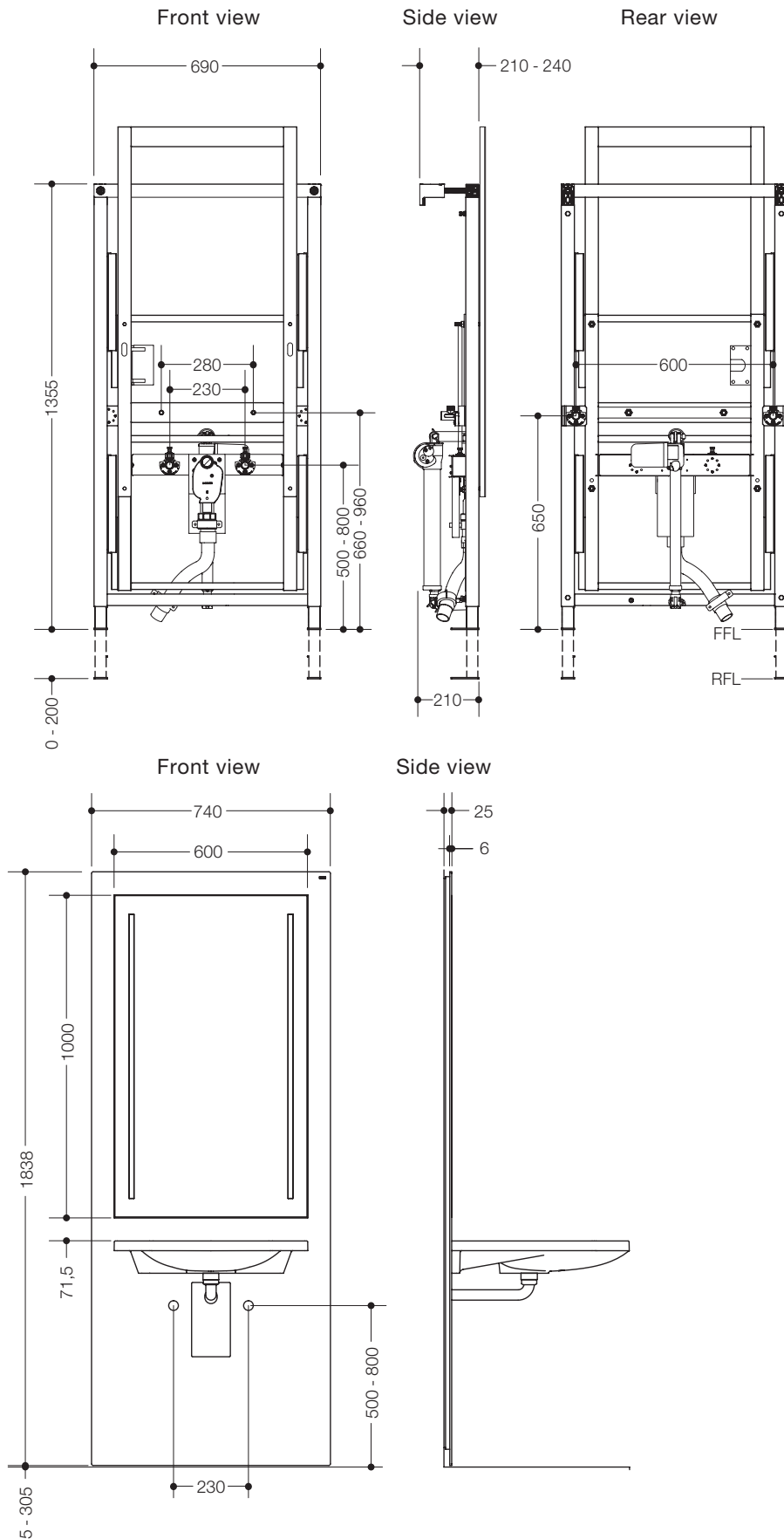

Toilet Module Product Dimensions

Front view

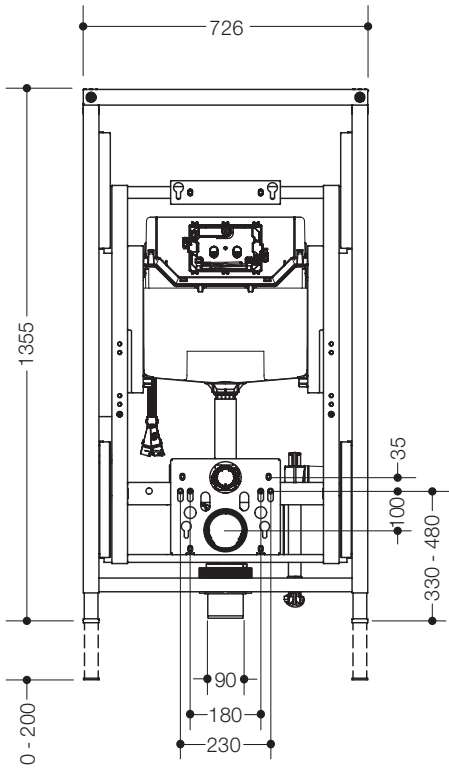

Side view

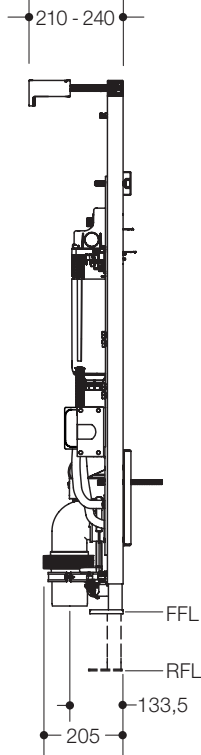

Floor gully: S50.02.01000, S50.02.02000

Rear view

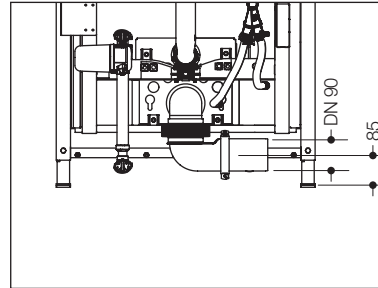

Side view

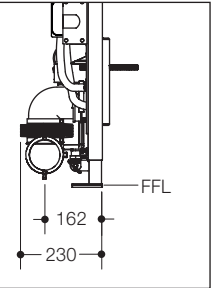

Left-hand side outlet: S50.02.01200, S50.02.02200

Rear view

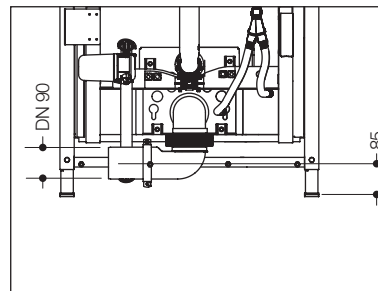

Side view

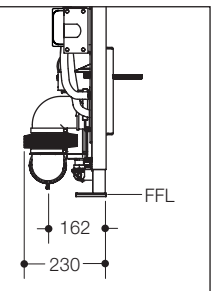

Right-hand side outlet: S50.02.01100, S50.02.02100

Front view

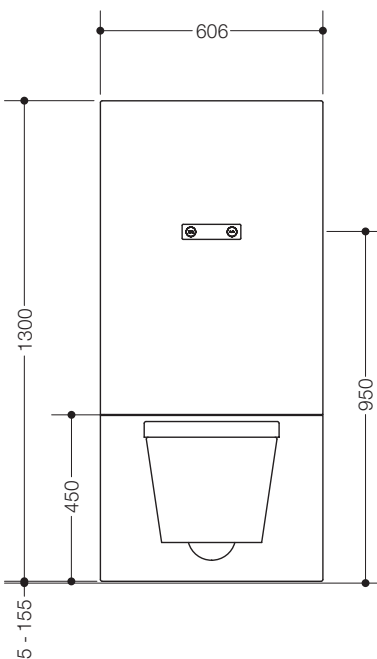

Side view

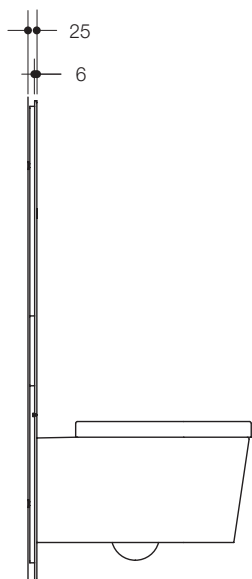

Positioning of the Drain

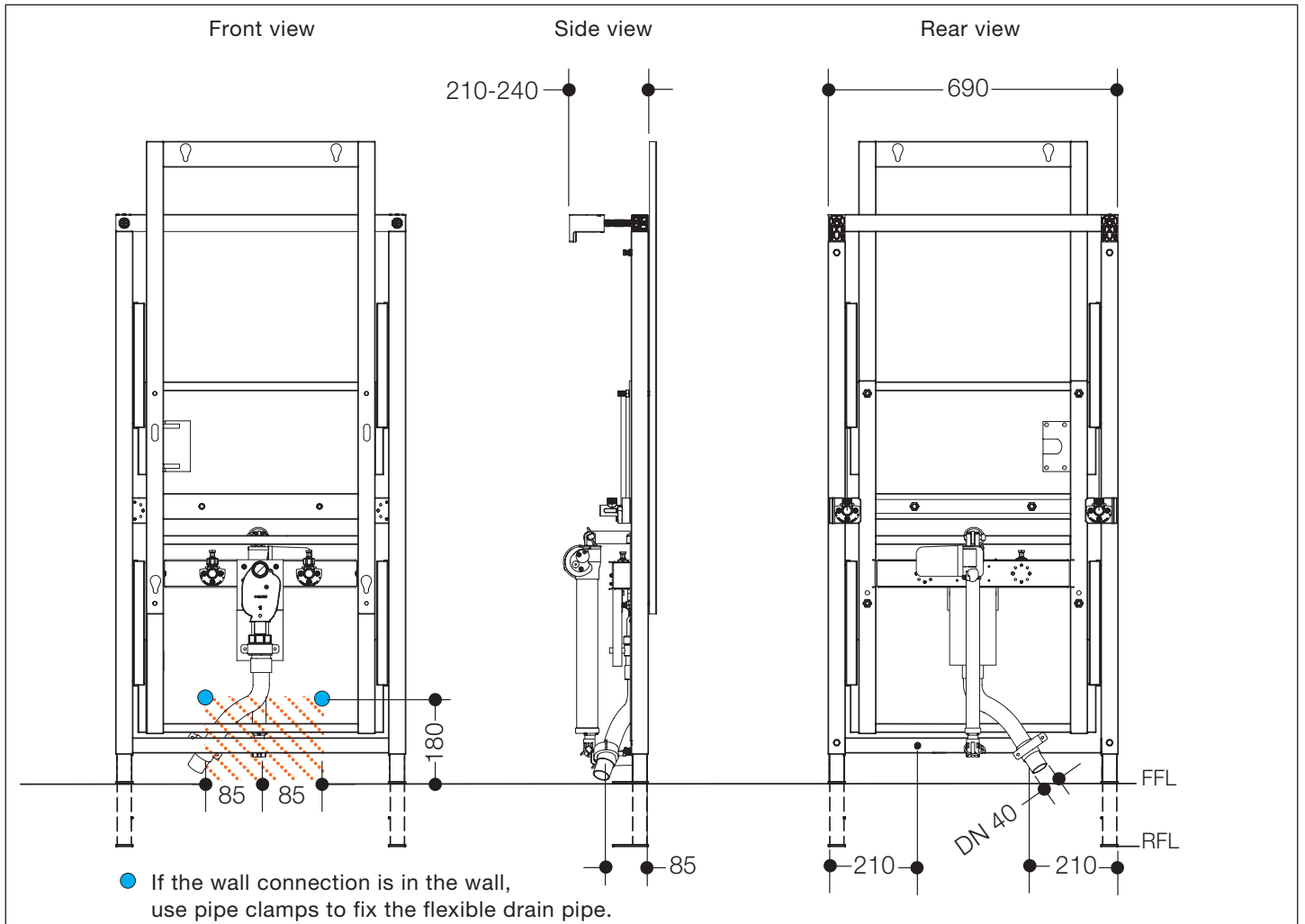

WASHBASIN MODULE

We recommend installing the drain (DN 40) as a floor gully. The discharge must not be centrally orientated (see hatched area). It is also possible to connect the drain discharge in the wall – this requires a clamp fixing (to be provided on site).

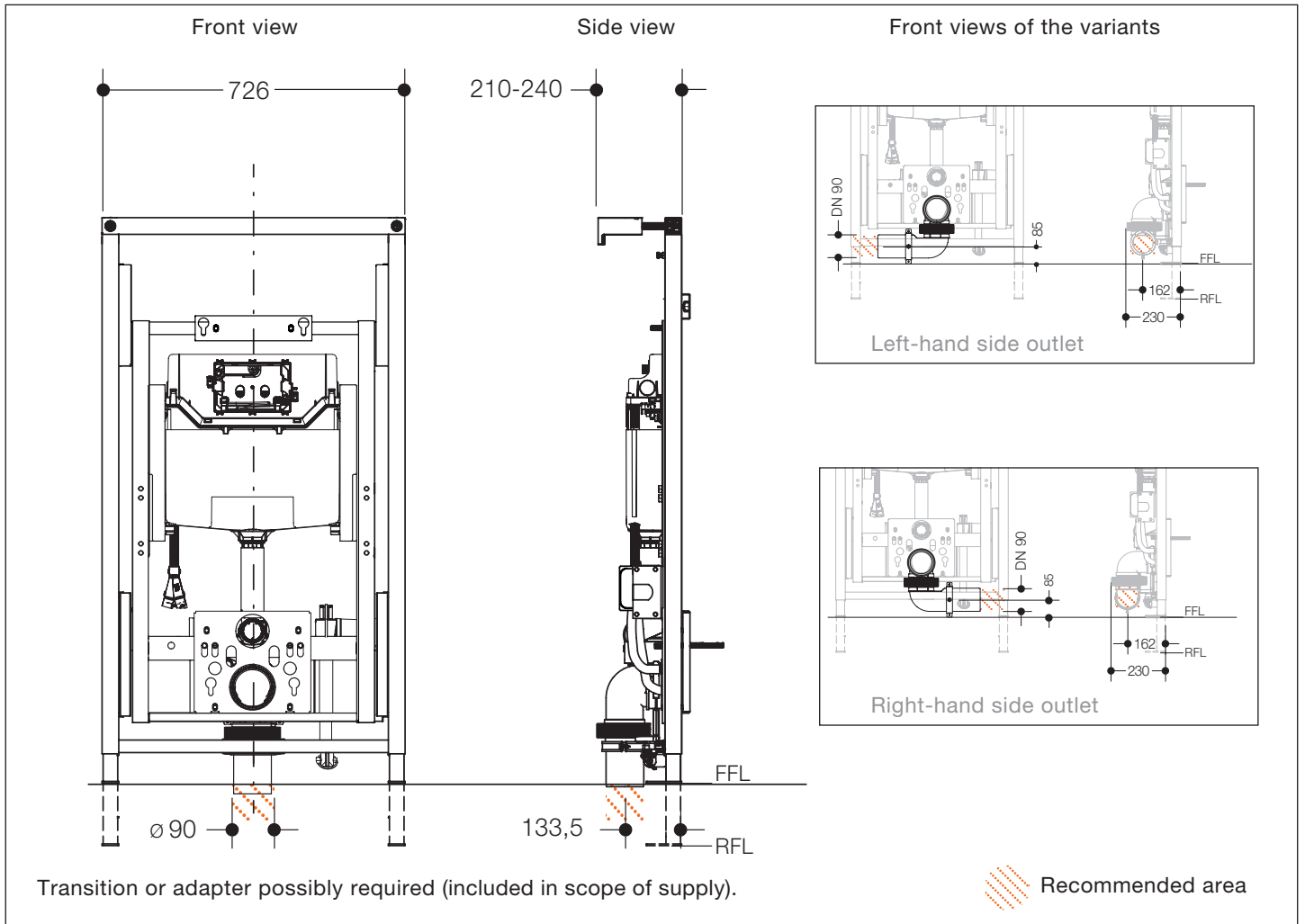

TOILET MODULE

The toilet module is optionally available with a floor gully or a side drain.

If the **floor gully** is selected, the drain in the floor must be connected in the specified position. The drain has a 90 mm diameter. Depending on the structural circumstances on site, it may be necessary to use an adapter (DN 90/110 transition, rubber adapter for sawn-off flange DN 90/110 or a transition made of PVC DN 90/100). These are included in the scope of supply.

If the **side outlet** is chosen, the outlet must not be more than 4 m from the riser. Depending on the structural circumstances on site, it may be necessary to use an adapter (DN 90/110 transition, rubber adapter for sawn-off flange DN 90/110 or a transition made of PVC DN 90/100). These are included in the scope of supply.

Positioning of the Water Connection

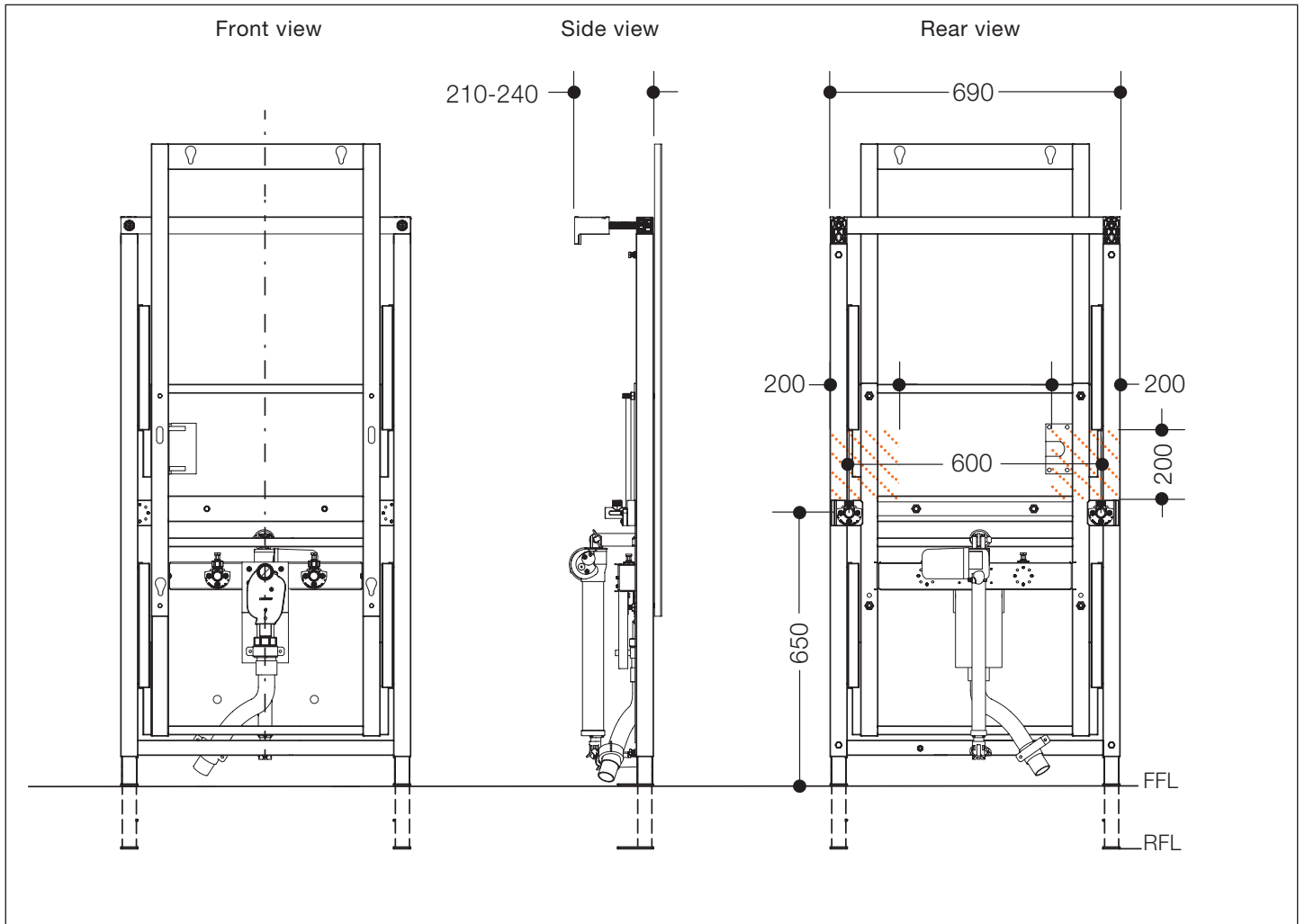

WASHBASIN MODULE

To ensure that the water connection ($\frac{1}{2}$ ") can be reached through the inspection opening following installation, it should be positioned in the area recommended by us (see hatched area). The elements for the water connection to the washbasin module do not move with the module itself. They are located on the prewall element at a height of 650 mm (the information refers to a prewall element with fixing feet in the bottom initial position/home position, see page 26).

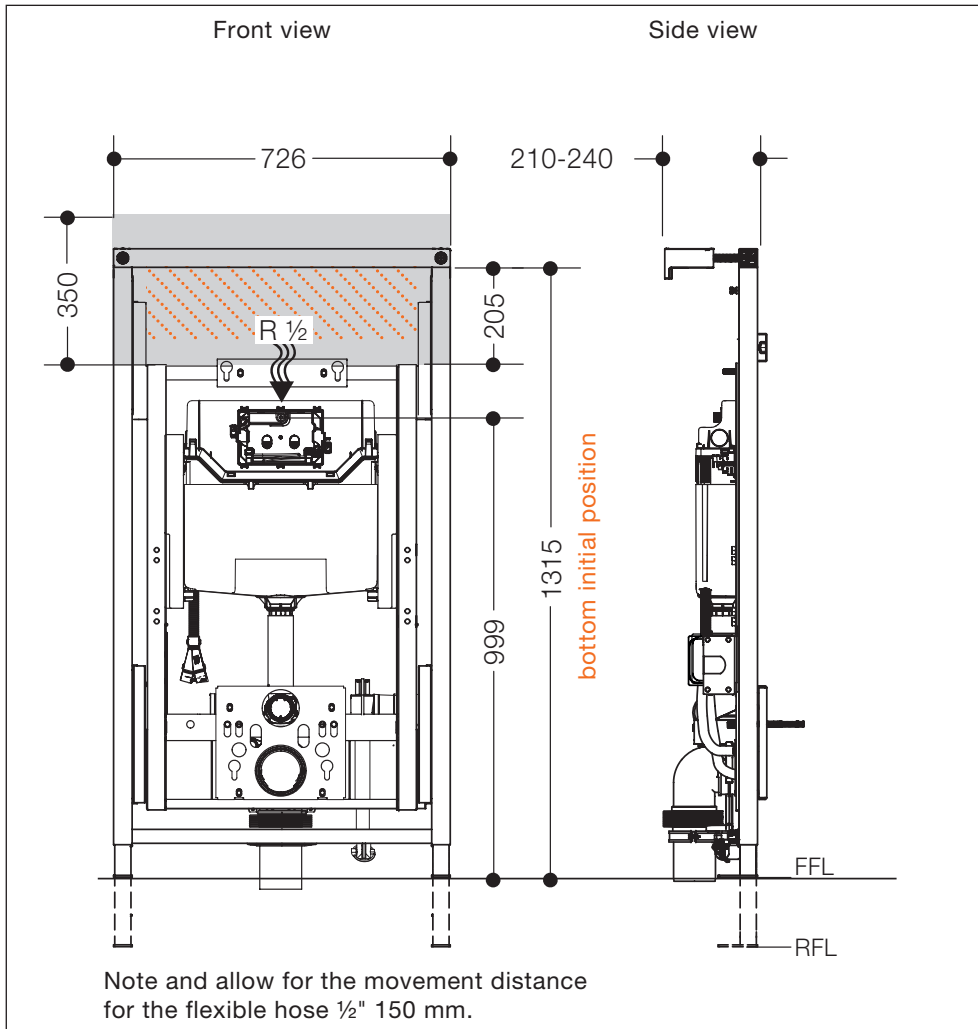

TOILET MODULE

The water connection of the toilet module must be made using a flexible hose (to be provided on site). When choosing the flexible hose it is necessary to allow for the movement of the cistern with the module (150 mm vertically).

Positioning of the Power Connection

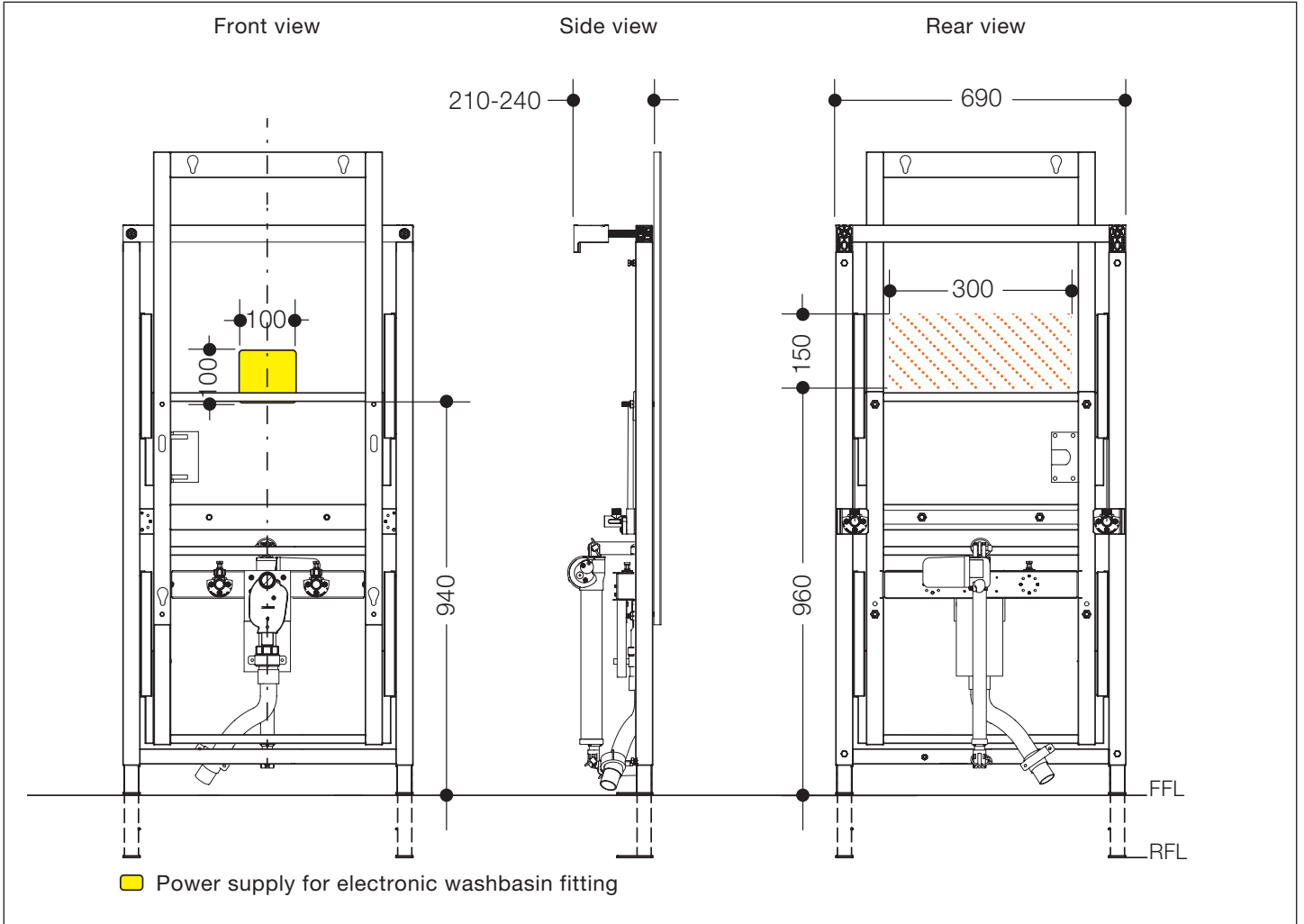

WASHBASIN MODULE

The washbasin module requires a 230 V power connection. A 2200 mm long cable with wire end ferrules is attached to the washbasin for direct power connection.

If the power cable is laid to a flush-type in-wall box, this can be freely positioned (the cable may then have to be extended). Please also read the notes on page 20-21.

If the power connection is planned with a surface-mounted on-wall box, this should be located within the recommended area (see hatched area).

We advise that the power connection be located within the recommended area (see hatched area) so that it is accessible for inspection.

The washbasin module with LED mirror requires a power connection (230 V) for the mirror. This can be provided separately, or combined with the power connection for the module motor (prewall element). In this case, the connection must lie within the recommended area, as the LED mirror is not connected until after the dry lining has been installed.

If an electronic washbasin fitting is provided, an additional power connection must be provided for the power supply of the fitting. Minimum cable length 1350 mm in the recommended area.

If the power connections are within the recommended area (see hatched area), they are easy to reach in case of inspection.

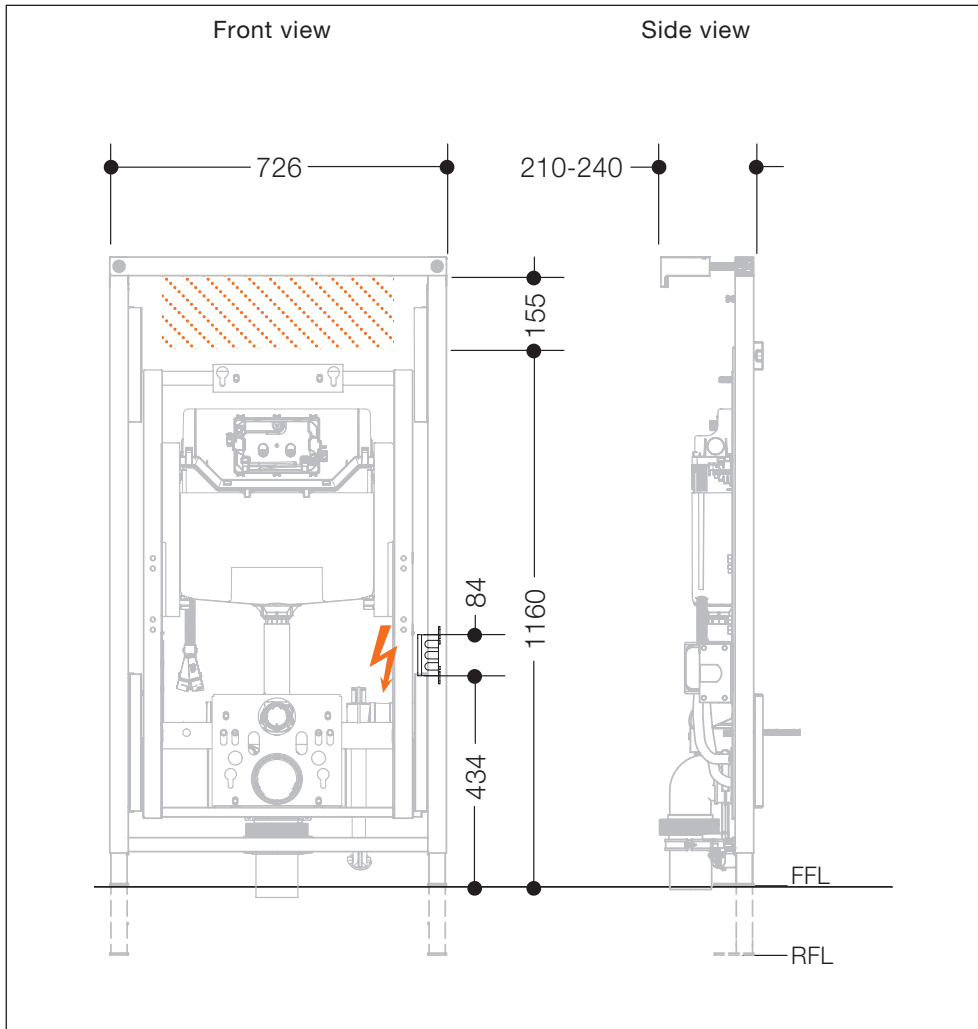

 Recommended area

TOILET MODULE

The toilet module requires a 230 V power connection. A 2200 mm long cable with wire end ferrules is attached to the washbasin for direct power connection.

If the power cable is laid to a flush-type in-wall box, this can be freely positioned (the cable may then have to be extended). Please also read the notes on page 20-21.

If the power connection is planned with a surface-mounted on-wall box, this should be located within the recommended area (see hatched area).

The sensor-controlled flushing mechanism requires a power connection for the cistern. This can be provided via the junction box (included in the scope of supply) of the power connection for the motor, or as a separate connection.

If the installation of a shower toilet is planned, an additional power connection must be provided for the toilet.

DIN VDE 0100-701 (VDE 0100 Part 701): 2010-08 applies to rooms with permanently installed shower, bath or whirlpool, which are used for showering or bathing. No protection areas are defined for washbasins, toilets and similar installations. The standard divides these rooms into three protection areas:

Area 0: The inside of the bath or shower tray forms area 0; no electricity sources are allowed here.

Area 1: Area 1 is bound by the finished floor and a notional horizontal surface at a height of 225 cm and the outside edges of the bath or shower tray, which form a notional vertical limiting face. Where baths or shower trays are bricked in, the inside edges of these form the vertical limiting face. Area 1 is additionally bound by the distance of 120 cm from the centre of the water discharge area (e.g. shower head) on the wall or in the ceiling in the case of showers without shower tray. The space under the bath or shower tray also belongs to area 1. No electricity source is allowed in this area either.

Area 2: Area 2 is bound by the finished floor and a notional horizontal surface at a height of 225 cm and by area 1 and the parallel surface at 60 cm distance. Area 2 is omitted for showers without a shower tray. In this case, the horizontal dimension of area 1 is increased to 120 cm. (See area 1).

Area 3: Area 3 is bound by the area at a distance of 240 cm from area 2.

The power connections of the S 50 height-adjustable modules may only be installed in areas 2 and 3 (and beyond).

To create a simple interface with the power supply, it is sufficient to integrate an on-wall box (protection class IP 44) in the wall during the shell and core construction phase.

If the installation of a shower toilet is planned, an additional power connection must be installed. If the shower toilet power connection is provided via a power socket, this may only be installed in area 3 (or beyond).

Installation | Wall Quality

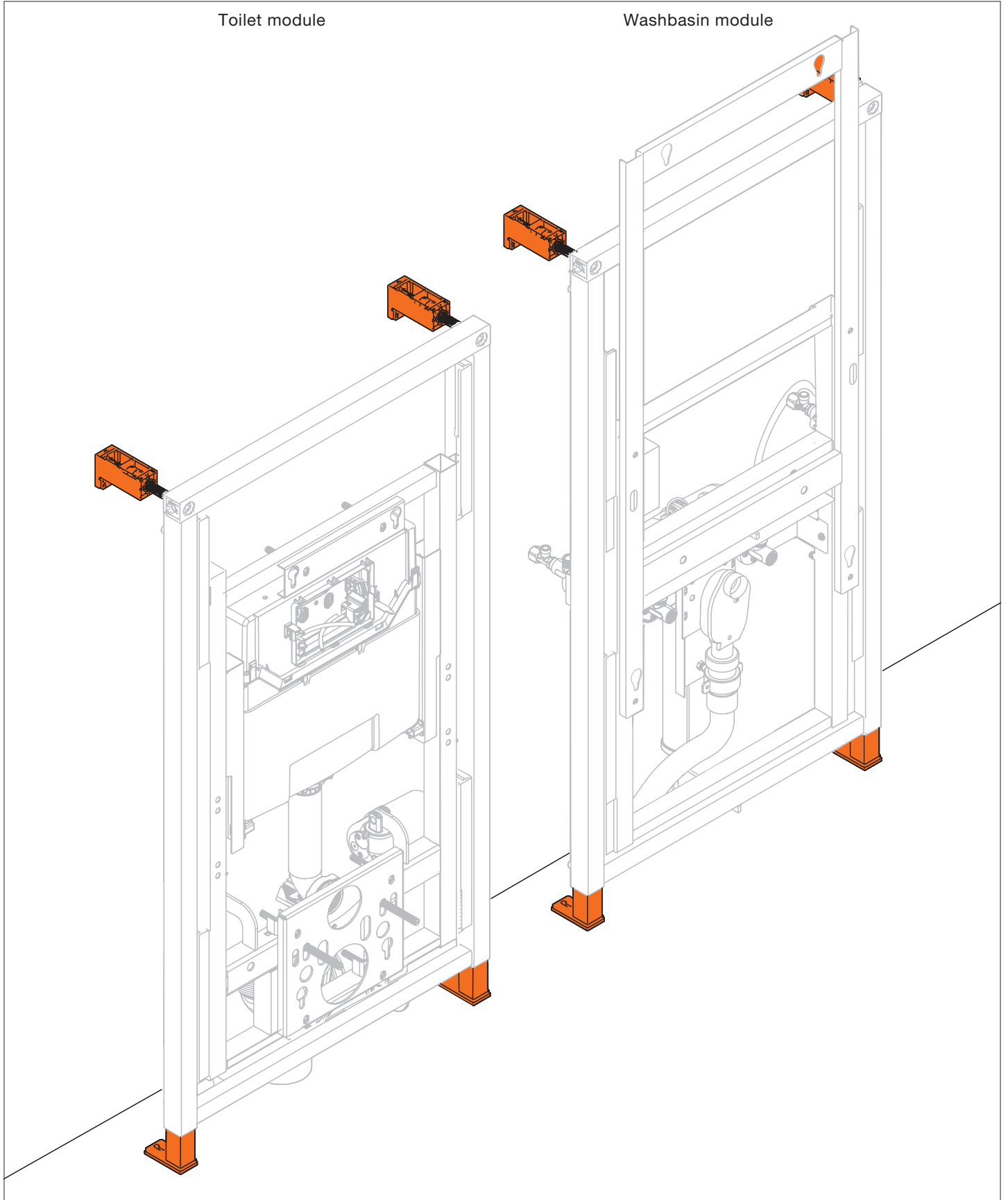

WALL QUALITY REQUIREMENTS

The modules require wall-floor installation. They cannot be placed as a freestanding element within the room. Wall-ceiling installation is also not possible. Floor-ceiling installation is only possible with corresponding dry wall sections (see pages 24-25).

The wall on which the prewall element is mounted must be as flat as possible. Unevenness in the wall can result in the module not being able to move. The walls must be able to carry a static load of at least 500 N (equal to around 51 kg) per fixing point. Walls made of concrete and solid calcium silicate blocks are suitable – in this case, you can use the fixing materials supplied. Walls made of perforated calcium silicate blocks, hollow concrete blocks, vertically perforated bricks, hollow lightweight concrete blocks, solid bricks or lightweight aggregate concrete with open structure are also suitable – please use the HEWI fixing material BM1288 for the installation. A minimum distance of 210 mm to the front edge of the prewall element must exist at each place on the wall.

Installation on walls that do not have the qualities described above (e.g. lightweight construction walls) is also possible. The basic requirement is that the walls must be able to carry a static load of at least 500 N (equal to around 51 kg) per fixing point. To this end, for example, an appropriate steel section (e.g. UA section by Knauf) must be used, which ensures that the static load can be absorbed. In this case the fixing material must be provided on site.

The fixing feet are sound insulated (isolated).

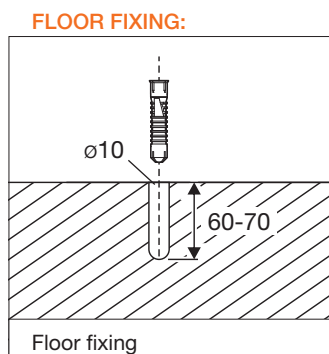
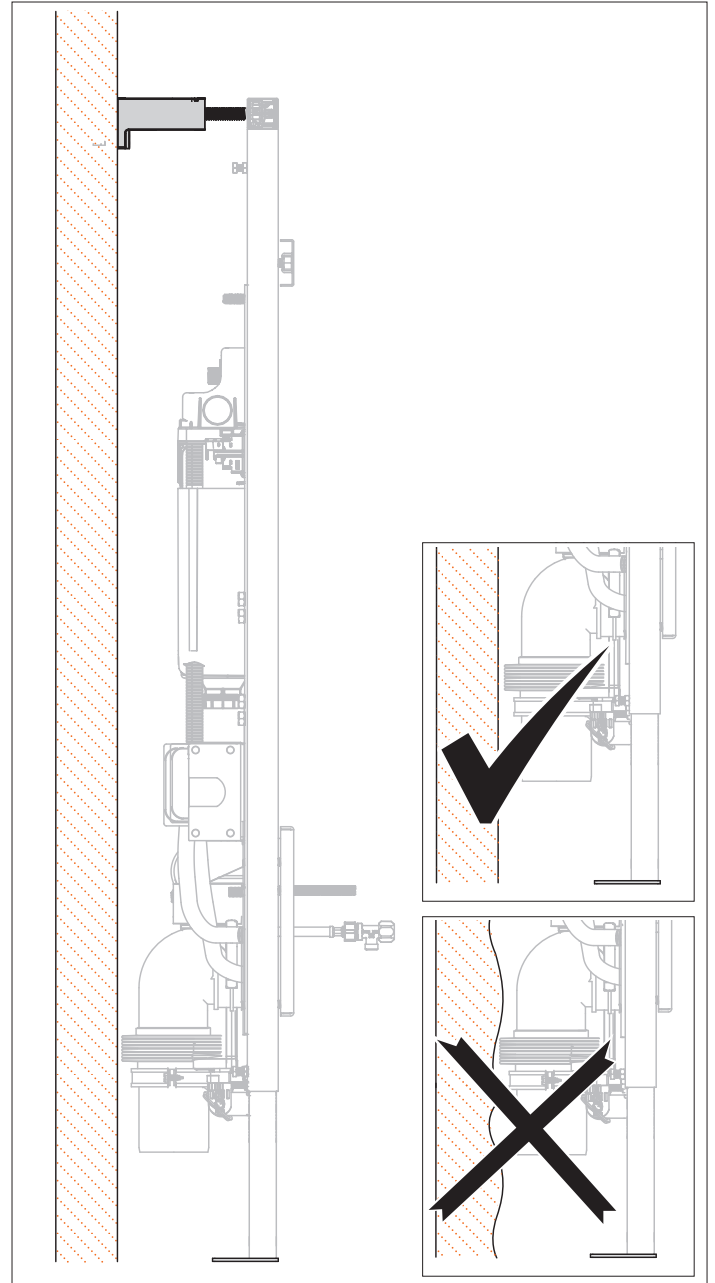

Included in the scope of supply.

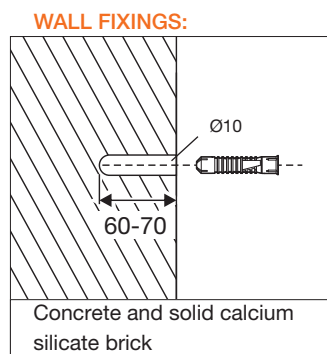

Included in the scope of supply.

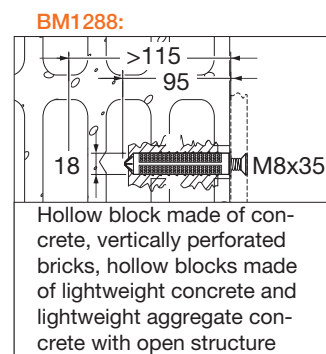

To be ordered separately.

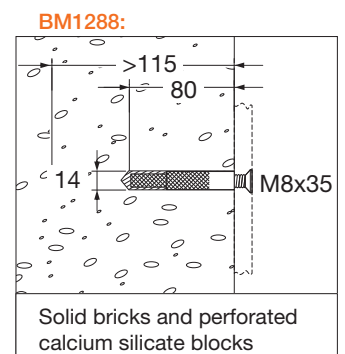

To be ordered separately.

Floor-ceiling installation

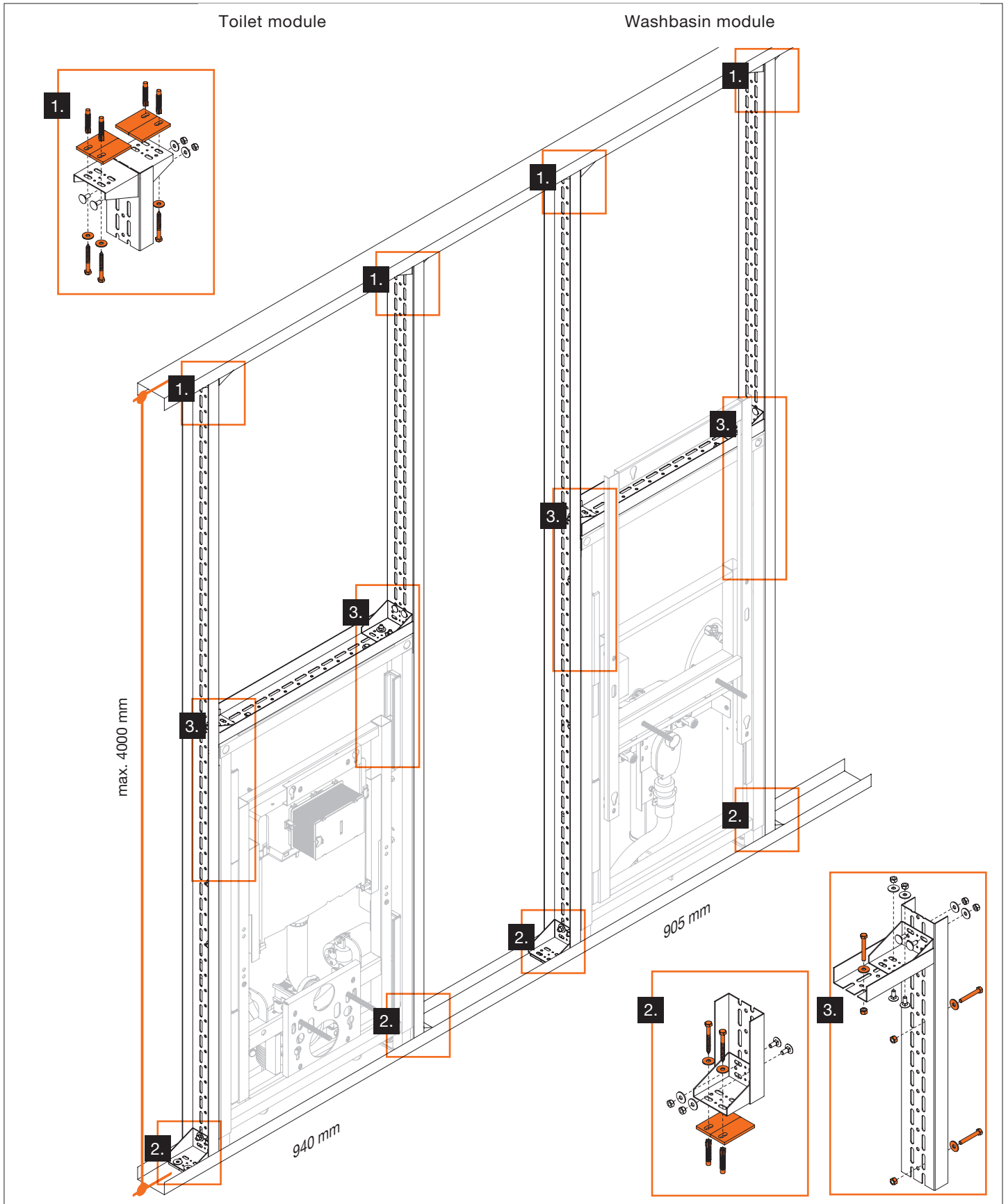





Floor-ceiling installation is possible with dry walling providing appropriate fixing material is used (BM 1305). Please note that the fixing material BM 1305 is not included as standard in the scope of supply and you have to order this separately.

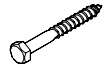

The basic requirement is that the walls must be able to carry a static load of at least 500 N (equal to around 51 kg) per fixing point. To this end, for example, an appropriate steel section (e.g. UA section by Knauf) must be used, which ensures that the static load can be absorbed. In the event of a dry wall structure, we recommend that you do not exceed a ceiling height of 4.00 m.

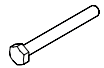
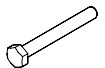
Information about the clearances required for the height-adjustable module can be found on page 28-29.

INCLUDED IN THE SCOPE OF SUPPLY

- | | | |
|---|---|---|
|  |  |  |
| 18x Washers (st. steel) | 12x Wood screws | 12x Wall plugs |
|  |  |  |
| 12x Sound insulation elements | 2x Screws M8x60 | 4x Screws M8x55 |
|  |  | |
| 6x Nuts | 8x Washers (polyamide) | |

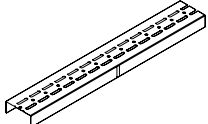
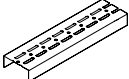
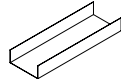
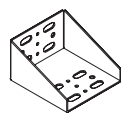
TO BE PROVIDED ON SITE

- | | |
|--|--|
|  | 2x UA section 100/40/2 Knauf |
|  | 1x UA section 100/40/2 Knauf 00003362 (2600 mm) |
|  | UW section 100/40/06 Knauf |
|  | 2x UA angle connector Knauf 00155861 (4 pieces each) |
|  | 1x sealing tape Knauf 00068984 (50 mm x 10 m) |

BM1305:

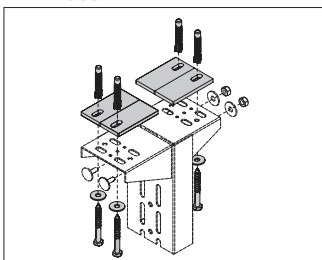

Fixing to dry walling reinforcement profiles

To be ordered separately.

Installation | Floor

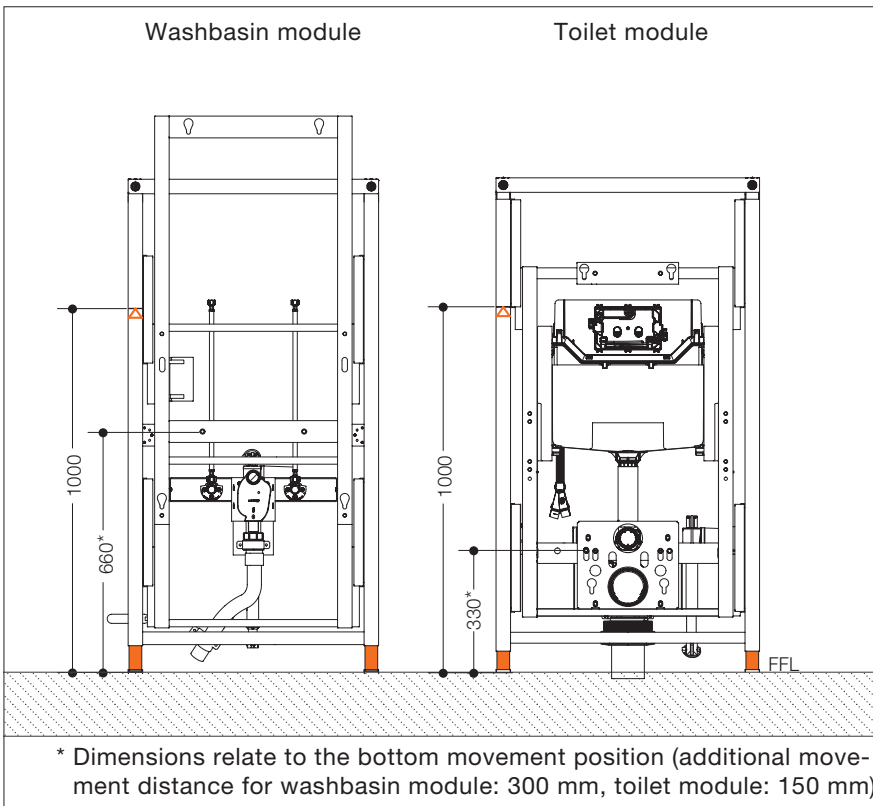

INSTALLATION ON THE FINISHED FLOOR FIXING FEET IN BASIC POSITION

The fixing feet of the prewall element can be mounted on the top of the finished floor. If the initial position of the washbasin or rather the toilet corresponds to the required height, the fixing feet of the prewall element remain unchanged (basic position).

The finished floor must have no gradient or unevenness.

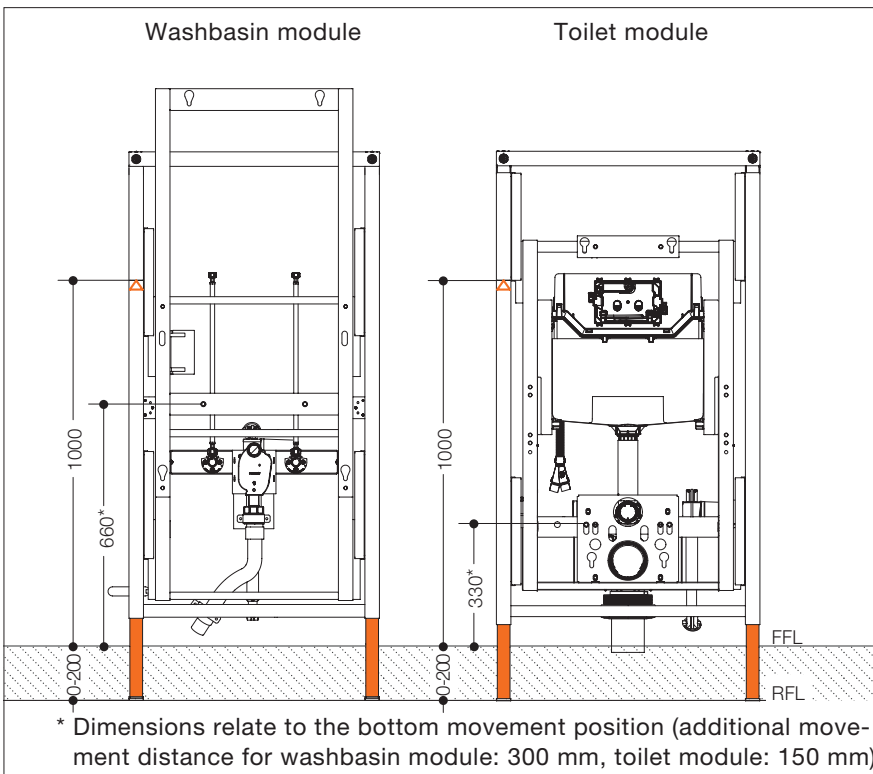

INSTALLATION ON UNFINISHED FLOOR FLOOR BUILD-UP 0 – 200 MM

If the fixing feet of the prewall element are mounted on the top of the unfinished floor, the fixing feet must be pulled out to at least the level of the planned surface of the finished floor. The total floor build-up must not exceed 200 mm.

The finished floor must have no gradient or unevenness.

Please note the build-up/height of the finished floor.

INSTALLATION ON THE FINISHED FLOOR FIXING FEET PULLED OUT

The initial position of the washbasin or rather the toilet can be changed, by pulling out the fixing feet of the prewall element before mounting it on the floor. The initial position can be changed by 200 mm maximum. In this way, the initial position of the toilet, for example, can be raised from the standard height of 420 - 425 mm to an accessible seating height of 460 - 480 mm. In this case it is necessary to extend the length of the drain pipe.

The finished floor must have no gradient or unevenness.

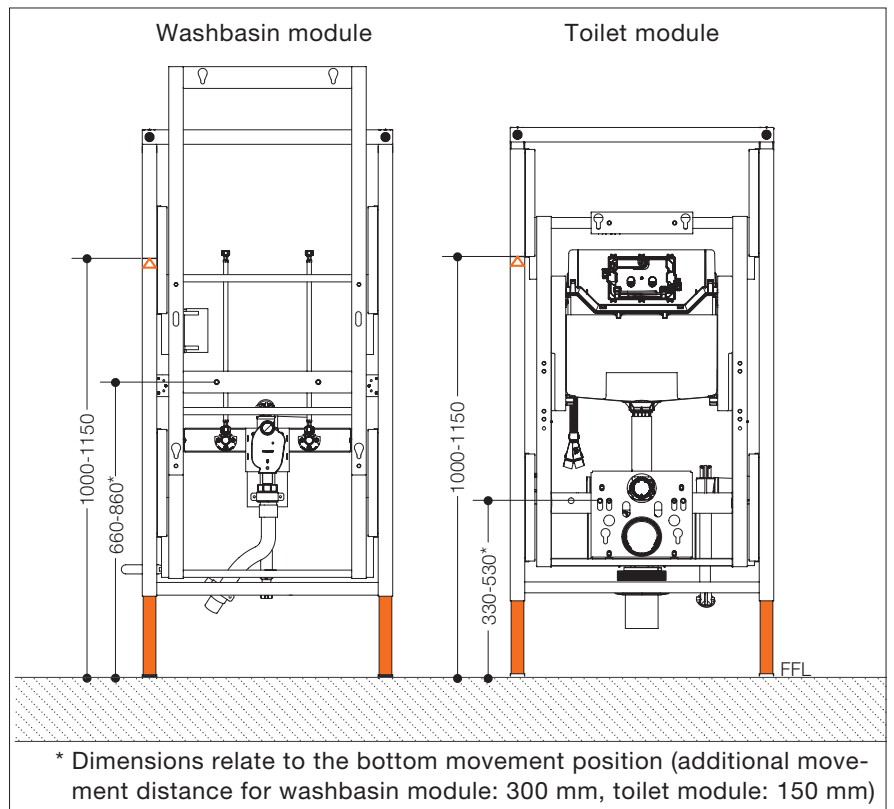

INSTALLATION ON UNFINISHED FLOOR, EXAMPLE: FLOOR BUILD-UP 75 MM

If the fixing feet of the prewall element are mounted on the top of the unfinished floor, the fixing feet must be pulled out to at least the level of the planned surface of the finished floor. The fixing feet can protrude beyond the surface of the finished floor. This is required, for example, to bridge a base or plinth tile (> 60 mm) (see page 33). In this case it is necessary to extend the length of the drain pipe.

The finished floor must have no gradient or unevenness.

Please note the build-up/height of the finished floor.

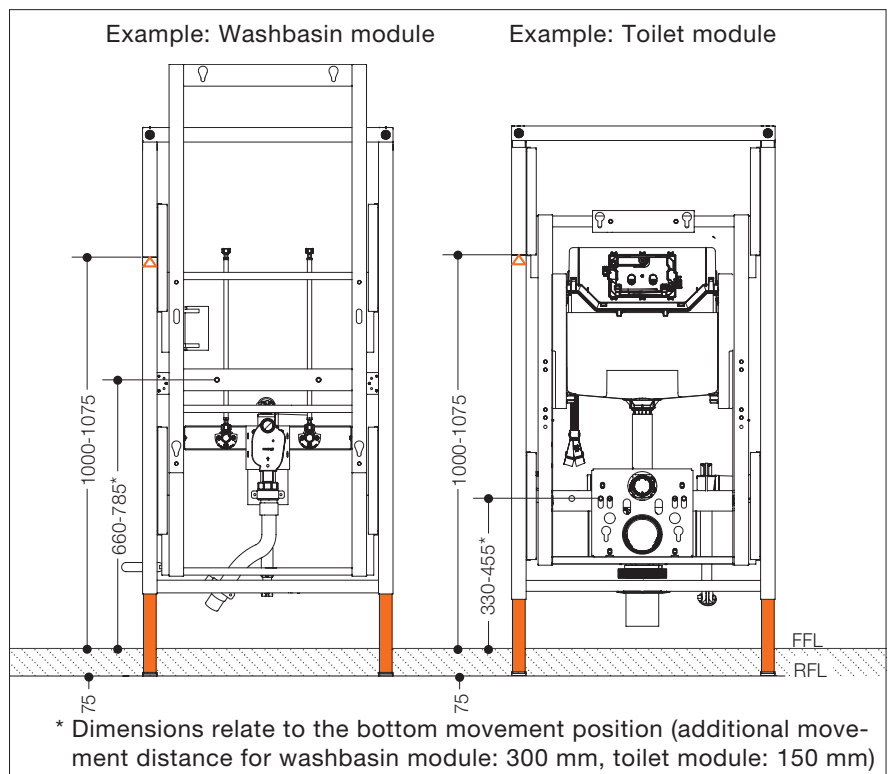

Required Clearances

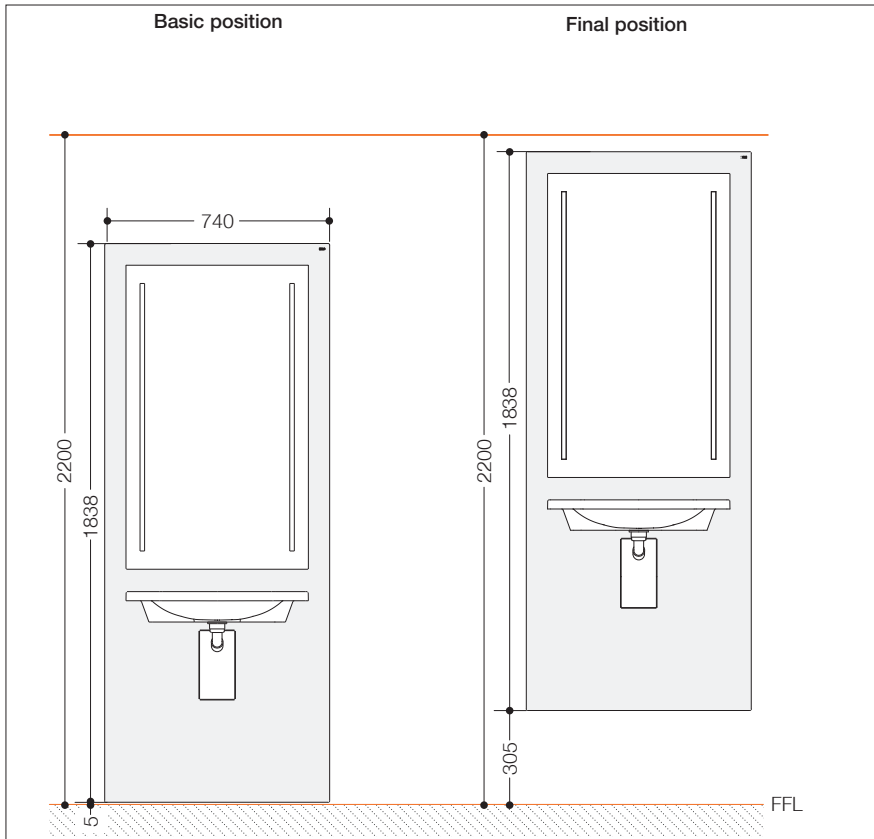

MINIMUM CLEARANCE OF THE WASHBASIN MODULE WITH FIXING FEET IN THE BASIC POSITION

Starting from the top of the finished floor, the clearance must be at least 2200 mm, to install the washbasin module.

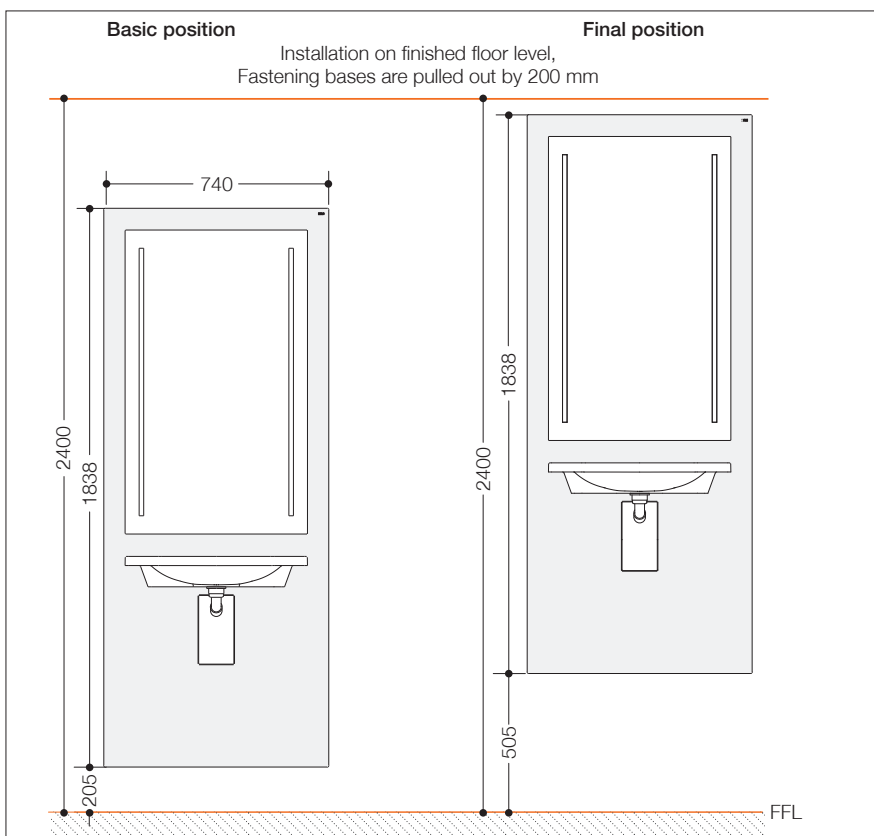

MINIMUM CLEARANCE OF WASHBASIN MODULE WITH FIXING FEET PULLED OUT

If the initial position of the washbasin has been increased (raised) by pulling out the fixing feet of the prewall element, this dimension (max. 200 mm) must be added to the 2200 mm.

MINIMUM CLEARANCE FOR TOILET MODULE WITH FIXING FEET IN THE BASIC POSITION

Starting from the top of the finished floor, the clearance must be at least 1505 mm, to install the toilet module.

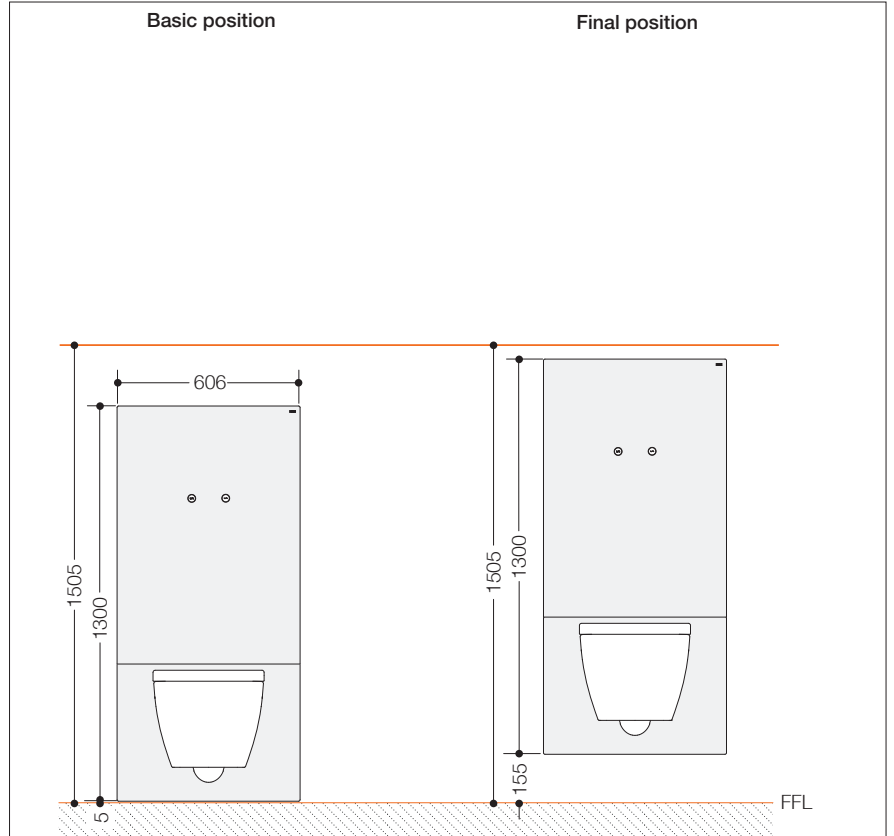

MINIMUM CLEARANCE OF TOILET MODULE WITH FIXING FEET PULLED OUT

If the initial position of the toilet has been increased (raised) by pulling out the fixing feet of the prewall element, this dimension (max. 200 mm) must be added to the 1505 mm.

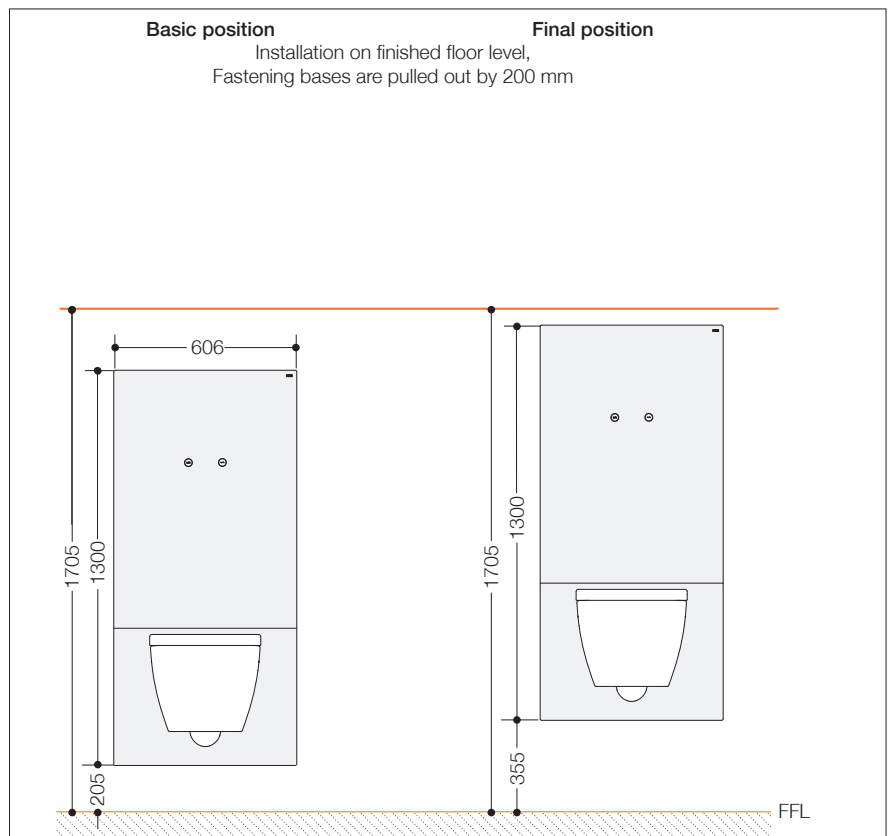

Required Distance from the Wall

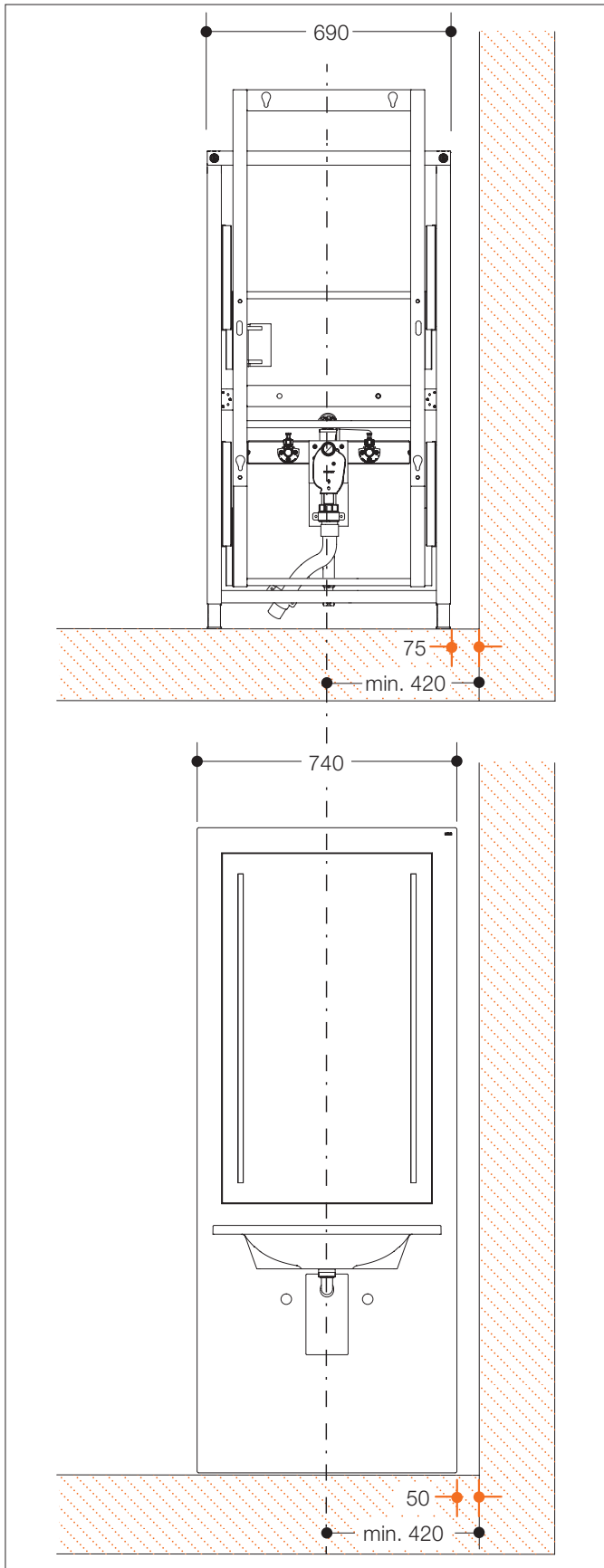

MINIMUM DISTANCE OF THE WASHBASIN MODULE FROM THE WALL

If the washbasin module is installed in the corner of a room, the distance from the prewall element to the wall must be at least 75 mm. This distance is required to mount the fronts during installation and to be able to remove them in case of inspection. The prewall element of the washbasin module is narrower than the front. The distance from the front to the wall must be at least 50 mm.

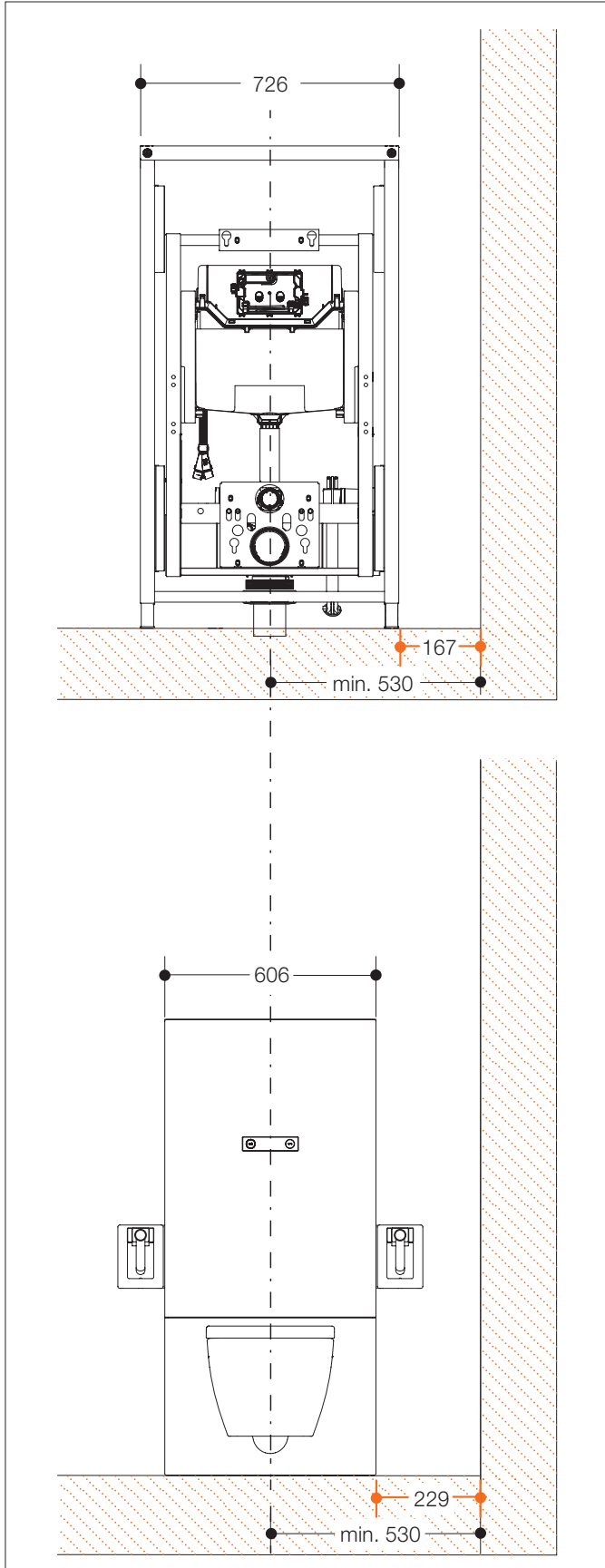

MINIMUM DISTANCE FROM THE TOILET MODULE TO THE WALL

If the toilet module is installed in the corner of a room, the distance from the prewall element to the wall must be at least 75 mm. This distance is required to mount the fronts during installation and to be able to remove them in case of inspection. The prewall element of the toilet module is wider than the front. The distance from the front to the wall must be at least 137 mm.

If a height-adjustable toilet module with hinged support rail is installed in the corner of a room, a distance of 167 mm from the prewall element to the wall is required, to be able to adjust the brake of the hinged support rail (corresponds to a distance from the front to the wall of at least 229 mm).

Dry Lining Requirements

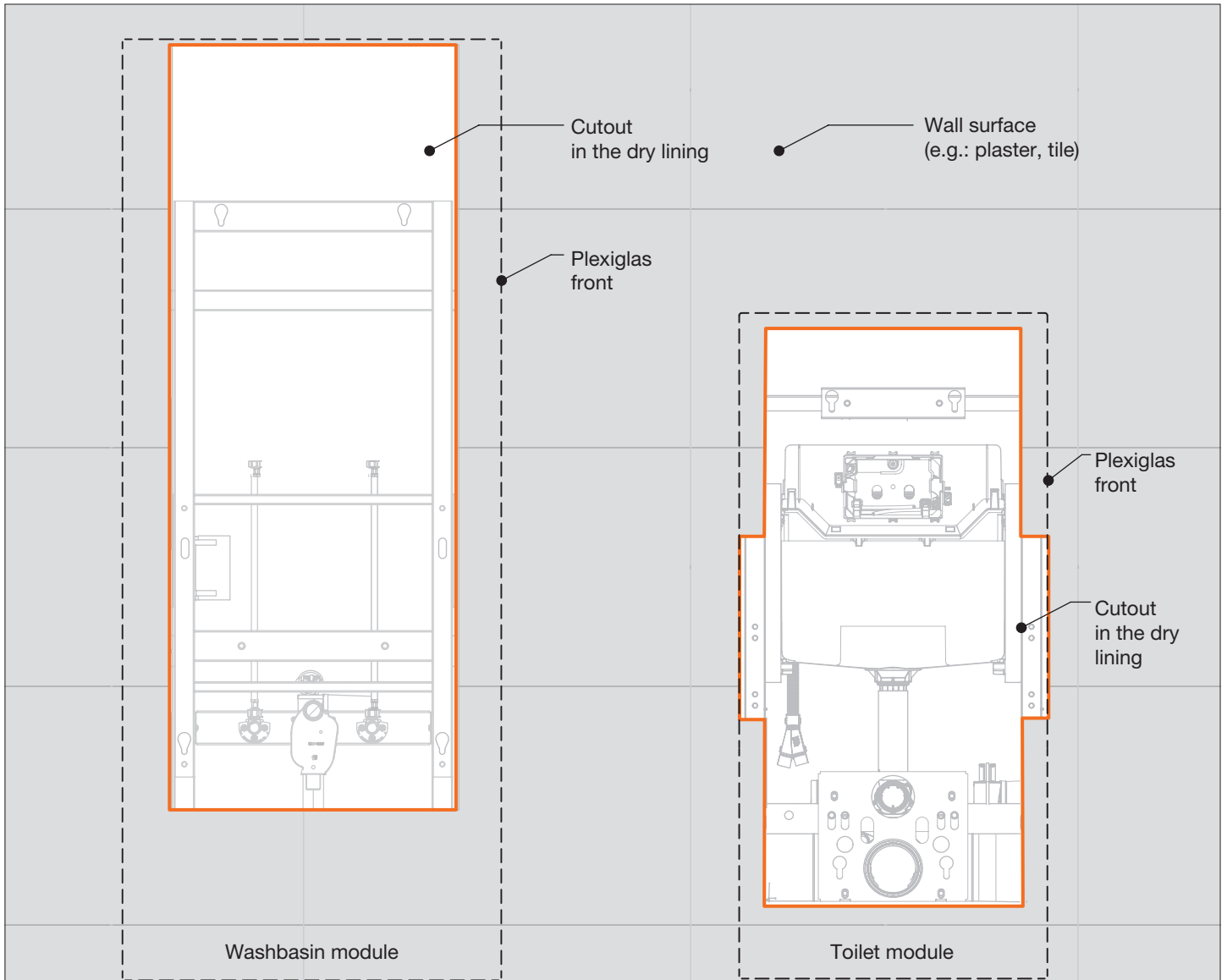

The wall surface (e.g. tiles) must extend exactly up to the edge of the dry lining boards. Please also read the notes in the installation instructions. The installation instructions are in the HEWI online catalogue.

We recommend a continuous wall build-up. If the prewall panelling is not ceiling-high (shelf area), appropriate sound insulation measures must be taken (to be provided on site) (SIA 181).

WC MODULE WITH HINGED SUPPORT RAILS

Holders for the mounting plates are required for the installation of hinged support rails.

The holders (item no. S50.02.00002) also serve as a mounting template for the drywall cut-out and should therefore be fitted beforehand.

Mounting on one side: 1x S50.02.00002

Mounting on both sides: 2x S50.02.00002



Maximum Thickness of the Wall Build-up

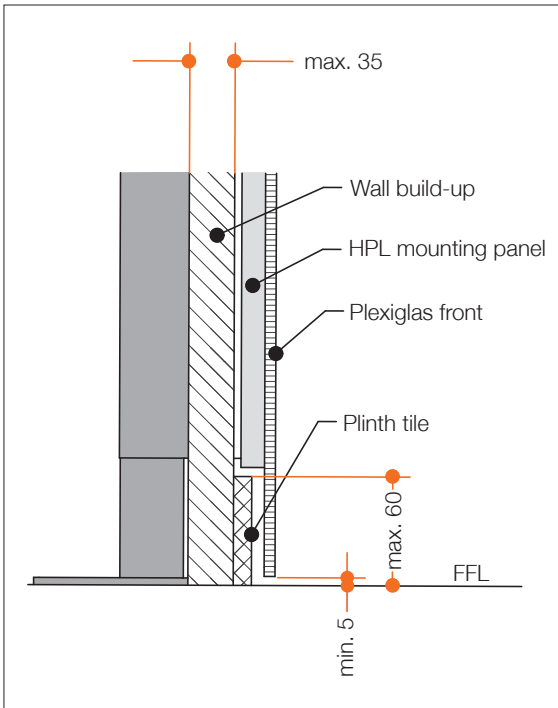

The wall build-up (dry lining wall sheathing and finished surface) must not be thicker than 35 mm.

FINISHED FLOOR REQUIREMENTS

The finished floor must have no gradient or unevenness.

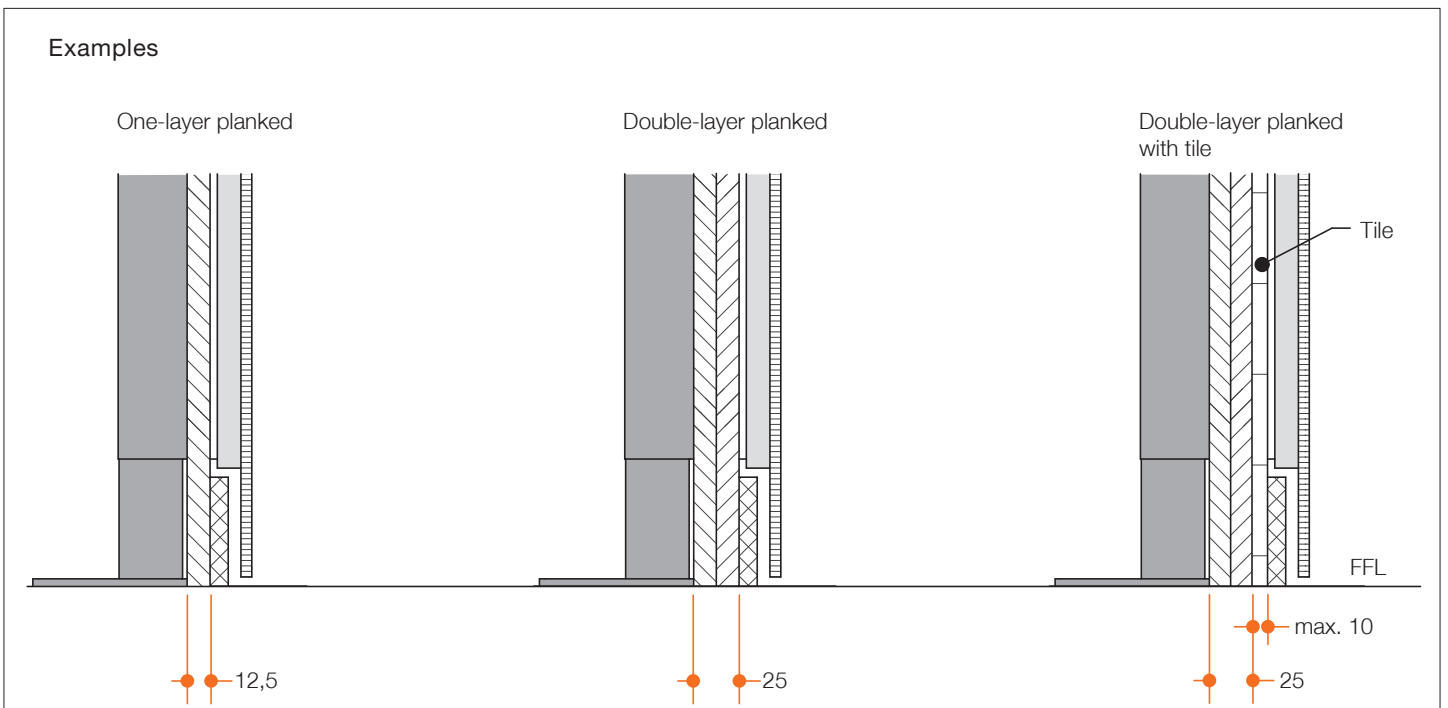

Integration in Studwork Elements

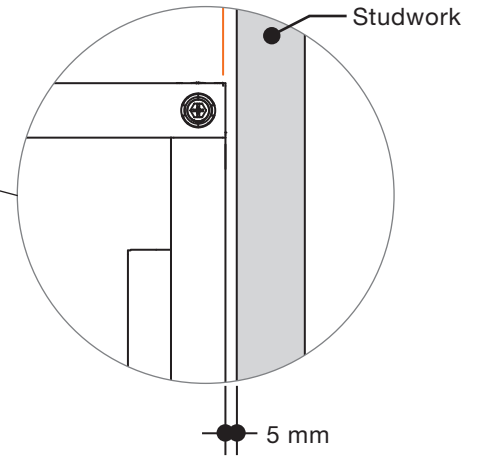
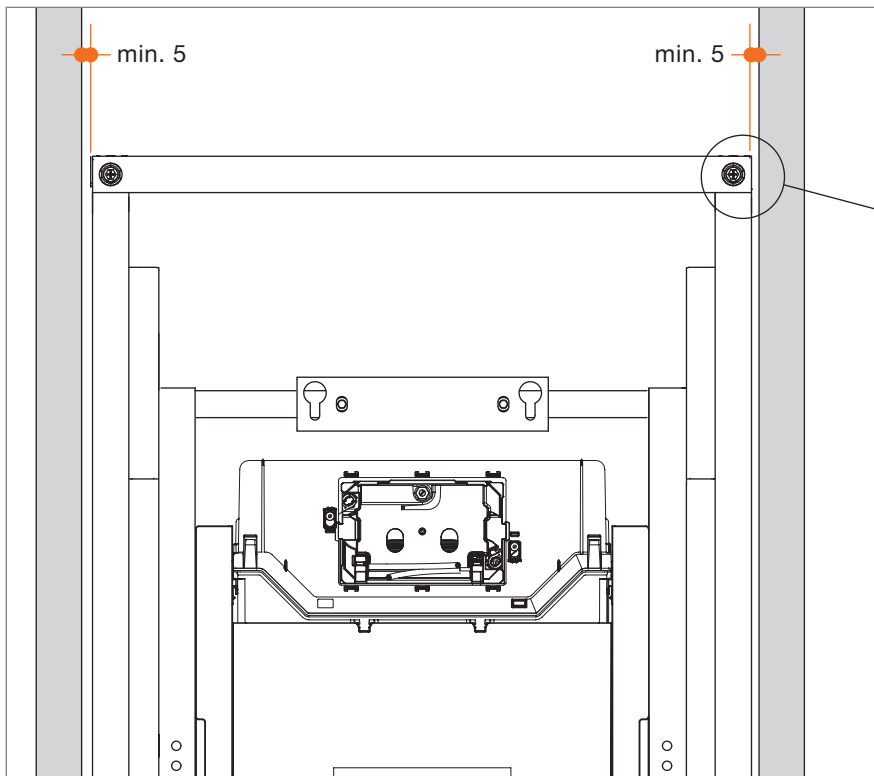

If the prewall element is not mounted (screwed) directly onto the studwork, a distance of 5 mm must be maintained between the prewall element and the studwork and no insulation tape may be used.

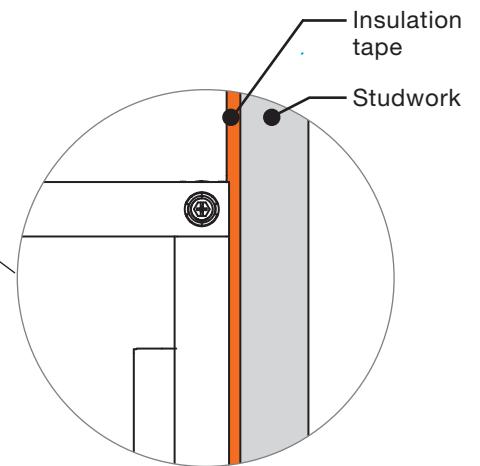
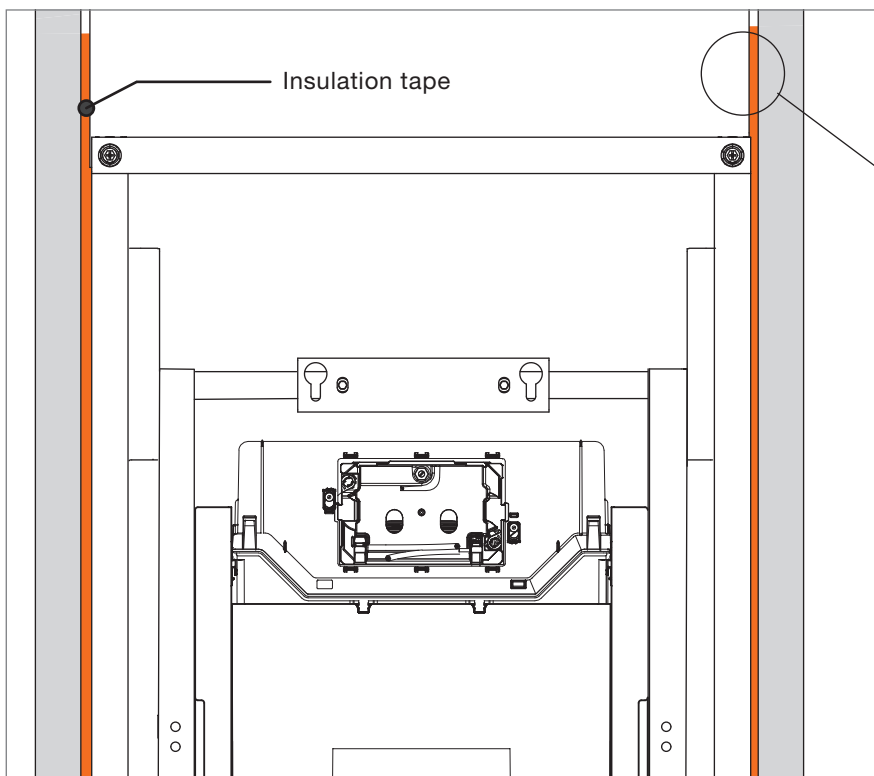

In case of direct mounting (screwing) of the prewall element on the studwork, an insulation tape (to be provided on site) must be used.

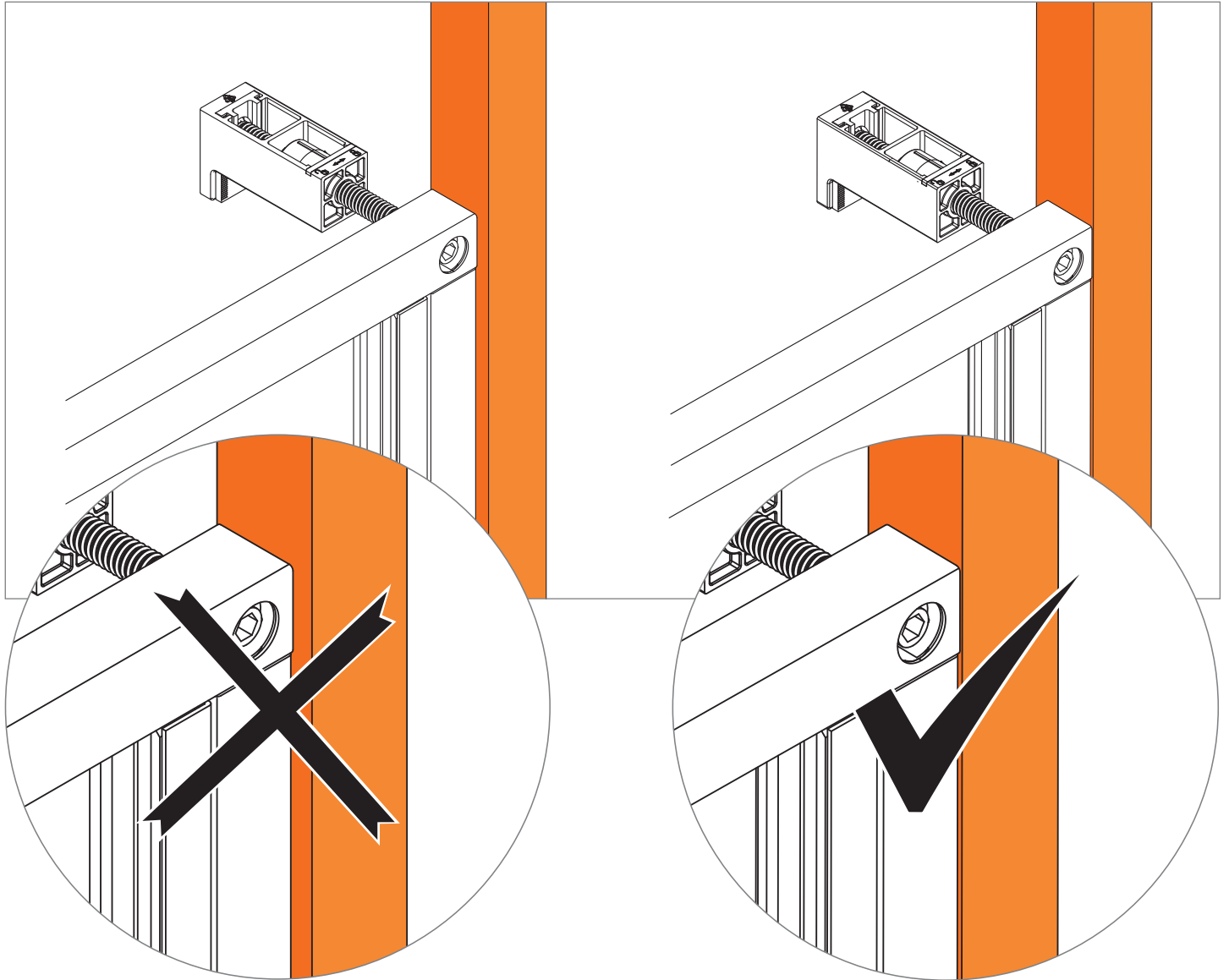

The prewall element must end flush with the studwork.

Minimum Spacing for Row Installations

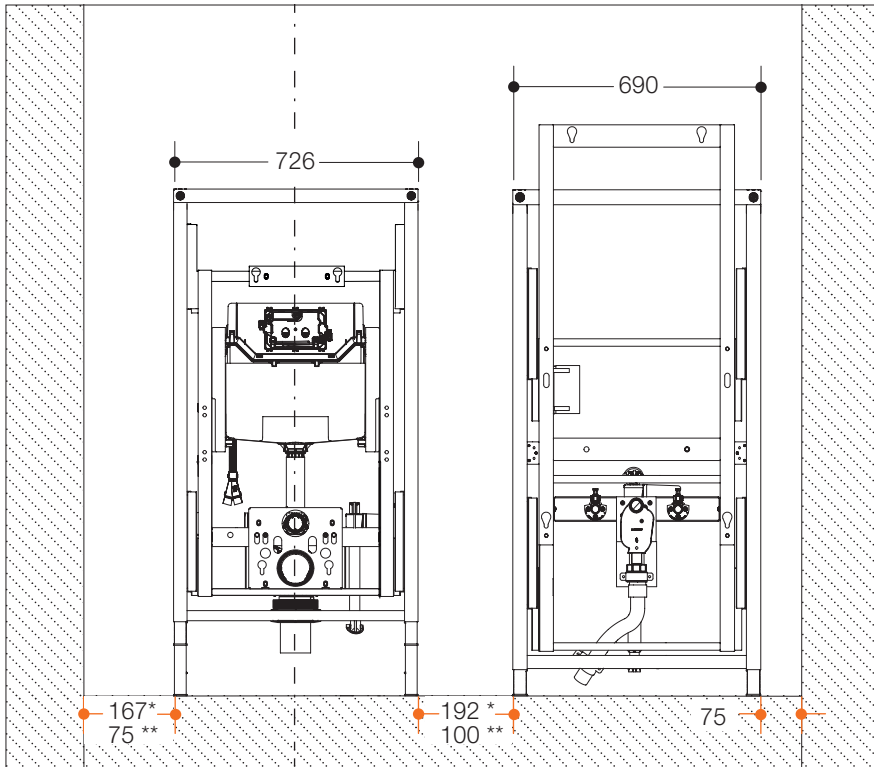

* with hinged support rails
 ** without hinged support rails

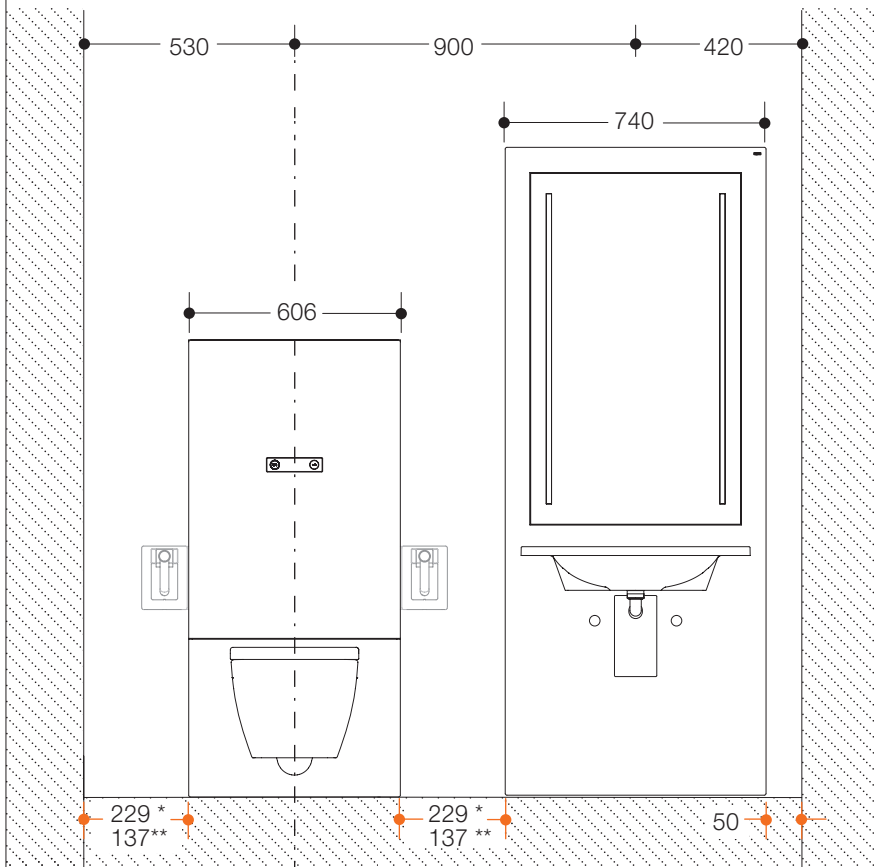

WASHBASIN AND TOILET MODULE

If a washbasin and toilet module with hinged support rails are to be installed next to each other as a row installation, a distance of 192 mm must be maintained between the prewall elements (corresponds to distance between the Plexiglas fronts of 229 mm). If a row installation consisting of a washbasin and toilet module without hinged support rails is planned, a distance of at least 100 mm must be maintained between the prewall elements (corresponds to a distance between the fronts of at least 137 mm). Retrofitting hinged support rails is then no longer possible.

WASHBASIN MODULES

If several washbasin modules are to be installed next to each other as a row installation, a distance of 100 mm must be maintained between the prewall elements (corresponds to distance of 50 mm between the fronts).

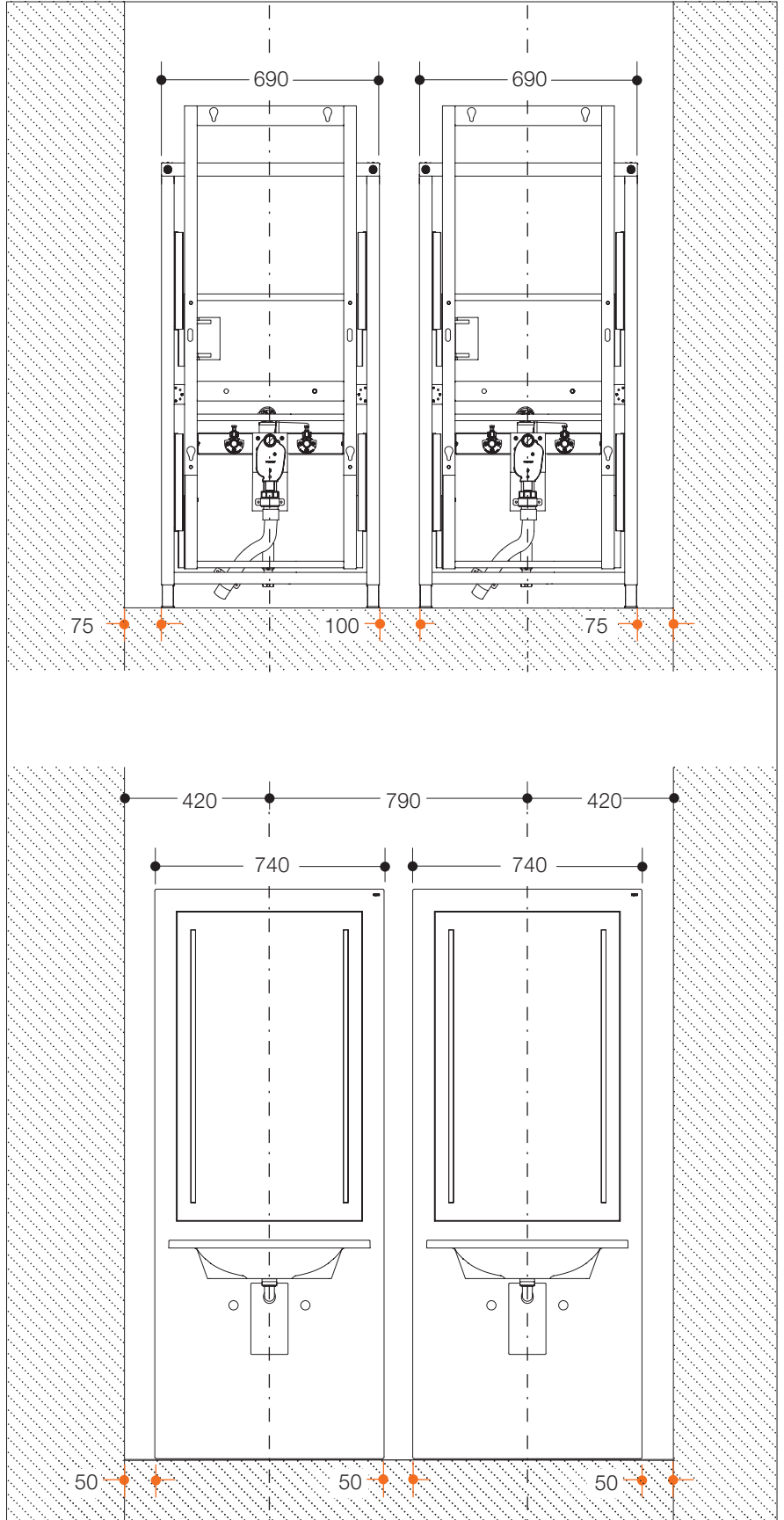

Positions of the Inspection Openings

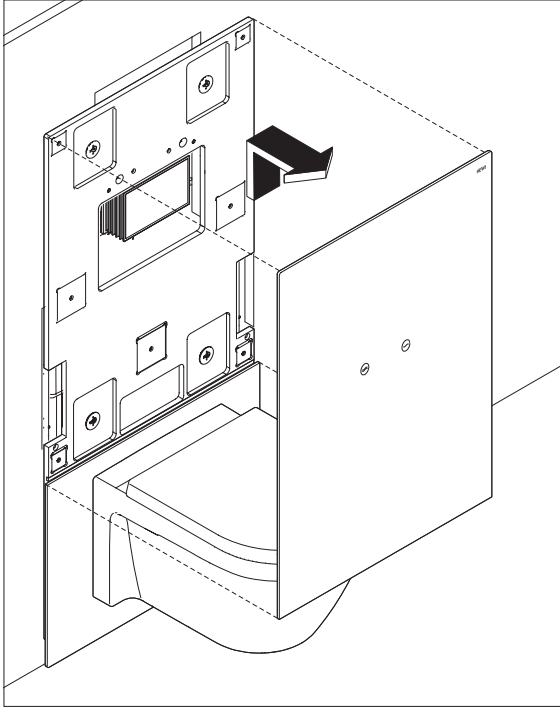

TOILET MODULE

The upper section of the Plexiglas front of the toilet module can be removed by lifting and unhooking it. When the front is open, all relevant components of the control and cistern can be accessed through an opening in the HPL mounting panel.

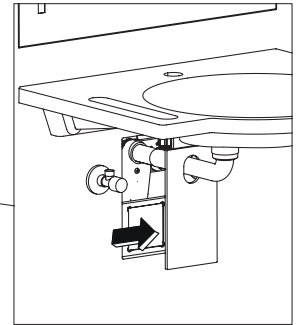
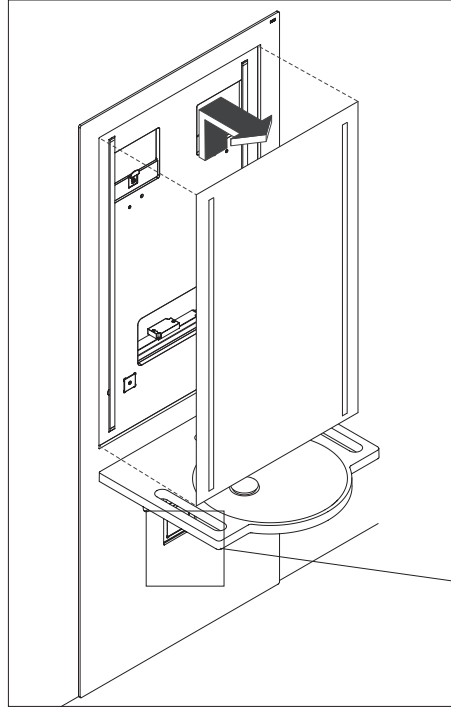

WASHBASIN MODULE

When the front is open, the trap can be accessed through an opening in the HPL mounting panel.

LED ILLUMINATED MIRROR

In case of inspection, all components of the LED illuminated mirror (ballast, radio receiver and light strips) can be replaced easily without dismantling the Plexiglas front. All components of the LED illuminated mirror are connected to each other by a push-fit connector system and can be replaced without tools. The mirror can be removed easily using the suction cup supplied.

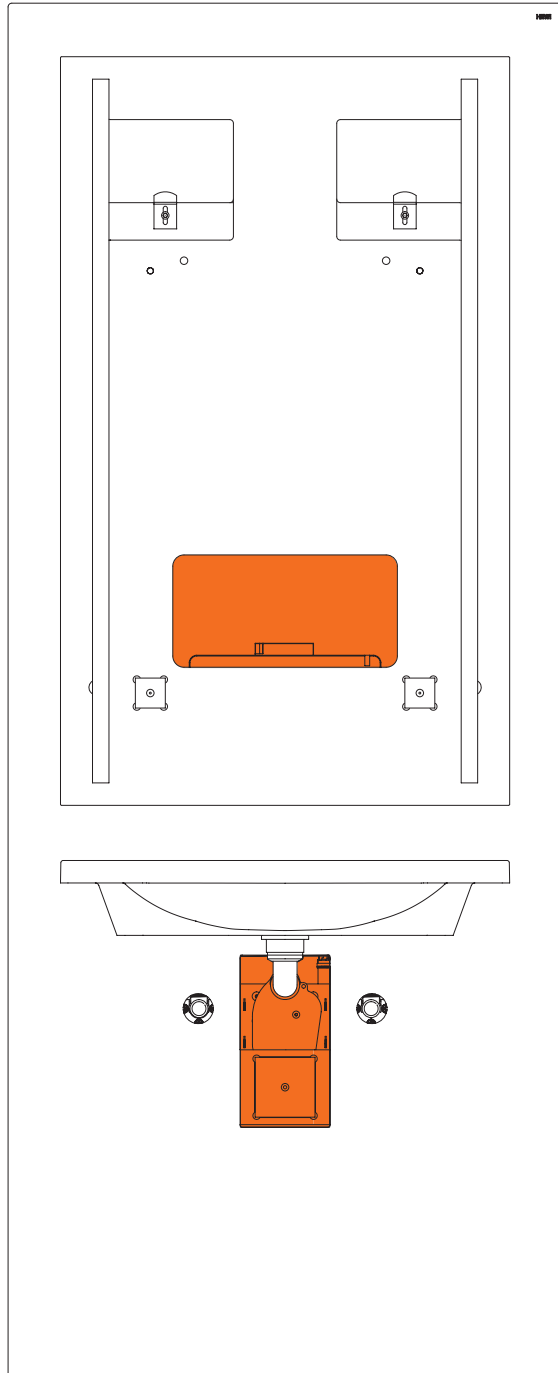

WASHBASIN MODULE

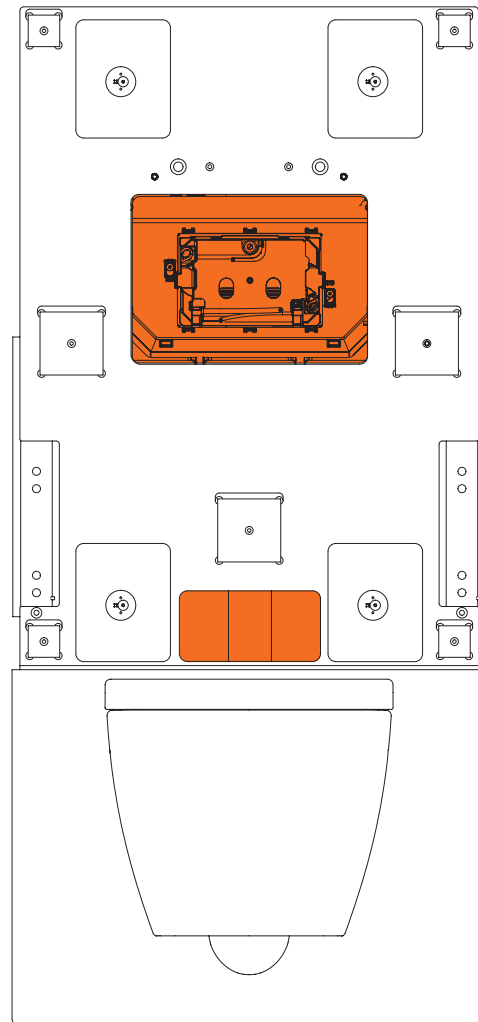

TOILET MODULE

Hinged support rails

Ordering information

- Add-on kits are divided into two article numbers
- The holder S50.02.00002 should also be ordered in the shell construction phase (pre-wall frame), as this serves as a mounting template for the drywall cut.
Mounting on one side: 1x S50.02.00002
Mounting on both sides: 2x S50.02.00002

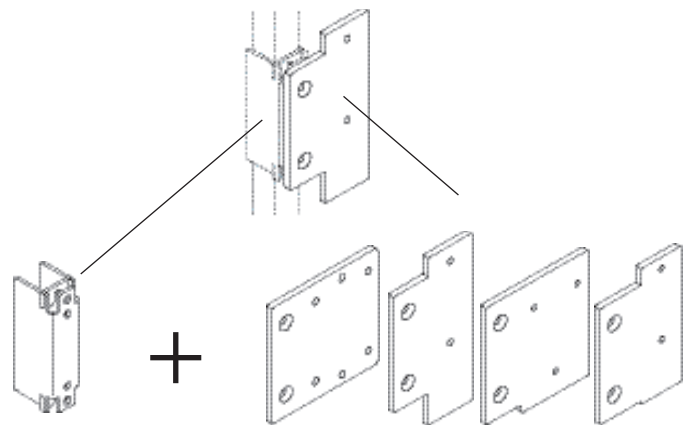

S50.02.00002

Hinged Support Rails Add-On Kit | Range 802 LifeSystem

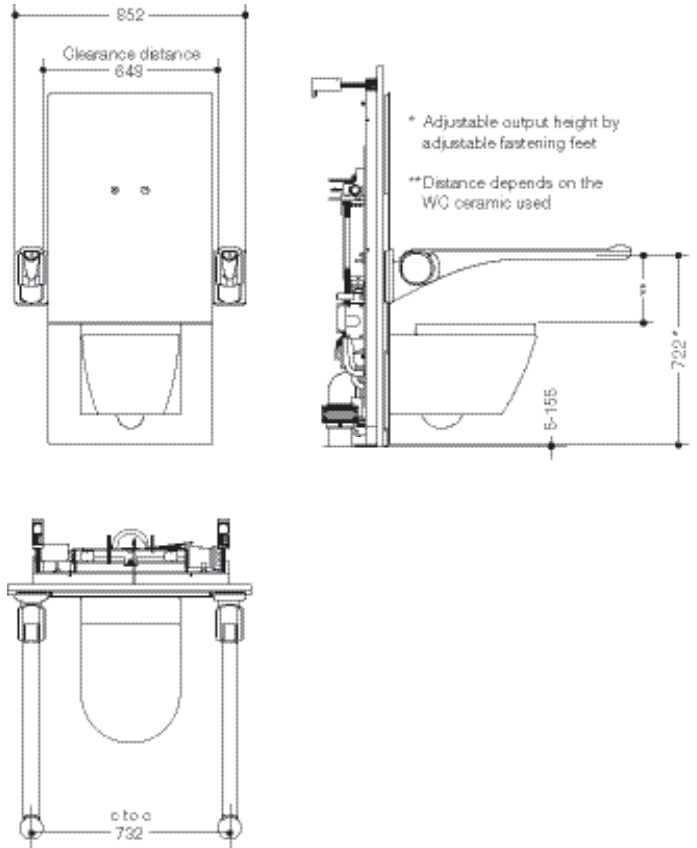

ADD-ON KIT S50.02.0003..

The toilet module can be equipped with range 802 LifeSystem hinged support rails on both sides or on one side only. Provided the required minimum distances (see pages 31,36) are complied with, the hinged support rails can be retrofitted at a later date.

The hinged support rails can be combined with the upgrade kit for the toilet flushing mechanism (radio controlled), if a sensor-controlled cistern is used (S50.02.02000, S50.02.02100 or S50.02.02200). A radio receiver (S50.02.02001) is also required for the sensor-controlled cistern. The backrest 802.51.90160 can be added to the range 802 LifeSystem hinged support rails. The hinged support rails (and the backrest) move with the toilet.

One add-on kit is required for each hinged support rail:

S50.02.00034 - left, seen from from user's view
 S50.02.00035 - right, seen from the user's view
 + S50.02.00002 - holder for mounting plate
 Fixing material is included in the scope of supply.



Range 802 LifeSystem hinged support rails
 802.50.4...

+ S50.02.0003... + S50.02.00002



Backrest | Range 802 LifeSystem
 802.51.90160

combinable with S50.02.0003...

Hinged Support Rails Add-On Kit | System 100 and 800

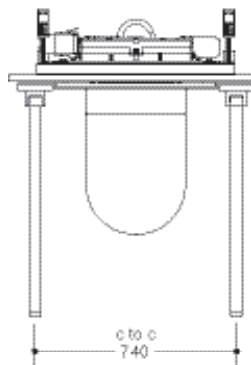
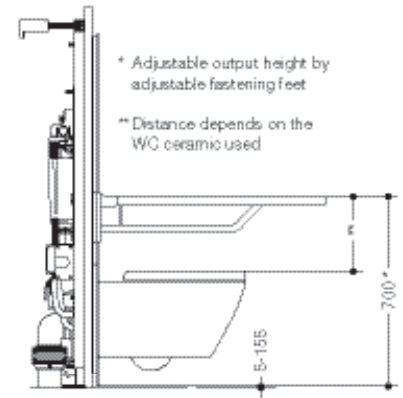
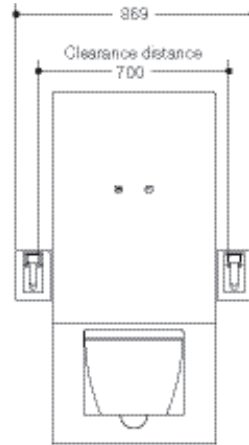

ADD-ON KIT S50.02.00021

The toilet module can be equipped with hinged support rails made of chrome (matching system 100 and 800), on both sides or on one side only. Provided the required minimum distances (see pages 31, 36) are complied with, the hinged support rails can be retrofitted at a later date.

The hinged support rails can be combined with the upgrade kit for the toilet flushing mechanism (radio controlled), if a sensor-controlled cistern is used (S50.02.02000, S50.02.02100 or S50.02.02200). A radio receiver (S50.02.02001) is also required for the sensor-controlled cistern.

A backrest rail cannot be added to the hinged support rails of system 100 and 800. They are not available as mobile variants.

The hinged support rails move with the toilet.

One add-on kit is required for each hinged support rail: **S50.02.00021**

+ **S50.02.00002** - holder for mounting plate

Fixing material is included in the scope of supply.

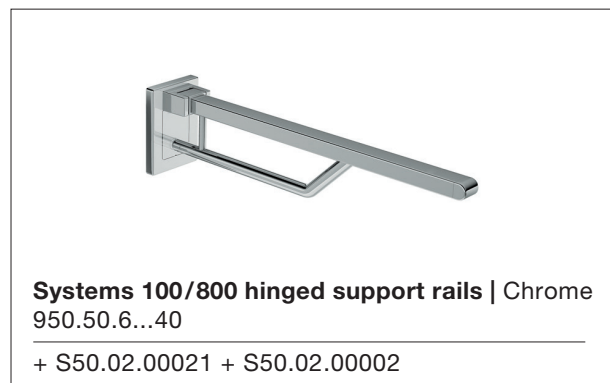

Hinged Support Rails Add-On Kit | System 800 K | WARM TOUCH

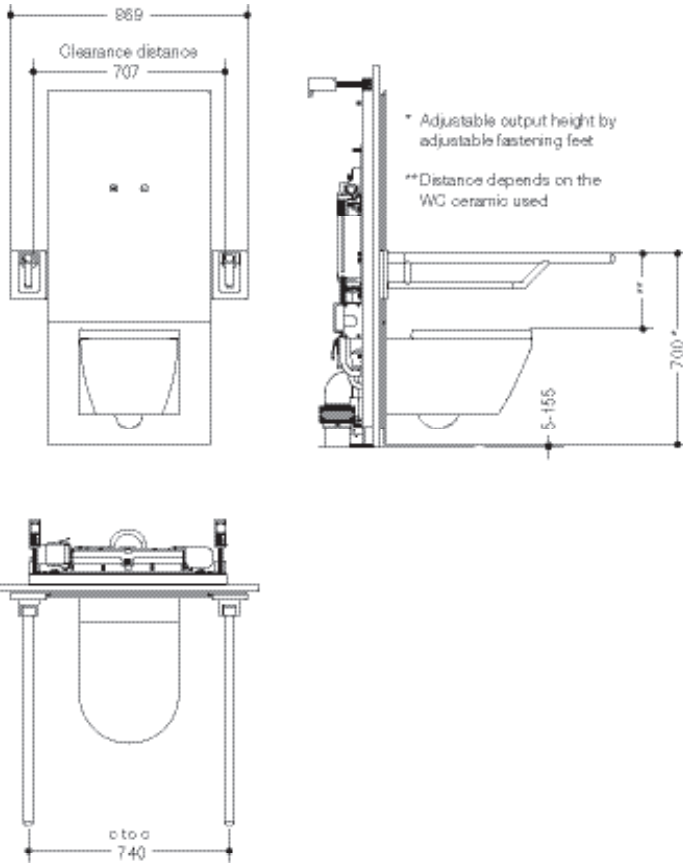

ADD-ON KIT S50.02.00021

The toilet module can be equipped with WARM TOUCH hinged support rails (matching system 162/chrome, system 800 and system 815) or made of polyamide (matching system 800 K), on both sides or on one side only. Provided the required minimum distances (see pages 29, 34) are complied with, the hinged support rails can be retrofitted at a later date.

The hinged support rails can be combined with the upgrade kit for the toilet flushing mechanism (radio controlled), if a sensor-controlled cistern is used (S50.02.02000, S50.02.02100 or S50.02.02200). A radio receiver (S50.02.02001) is also required for the sensor-controlled cistern. A backrest rail cannot be added to the hinged support rails of system 800 K and WARM TOUCH. They are not available as a mobile variant. The hinged support rails move with the toilet.

One add-on kit is required for each hinged support rail: **S50.02.00021**

+ **S50.02.00002** - holder for mounting plate

Fixing material is included in the scope of supply.

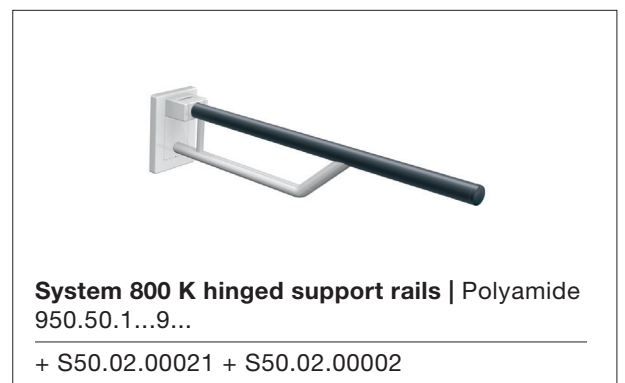

Hinged Support Rails Add-On Kit | Range 805 Classic | Range 801 | System 900 design B

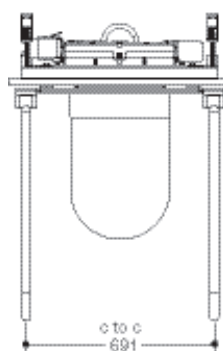
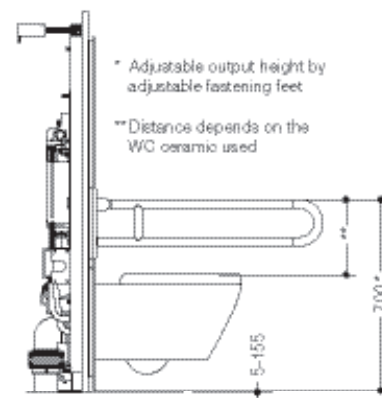
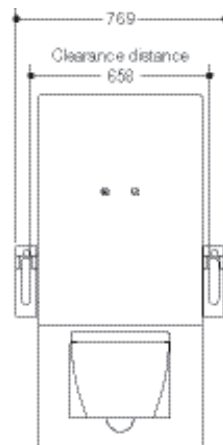

ADD-ON KIT S50.02.0001..

The toilet module can be equipped with hinged support rails made of stainless steel (matching range 805 Classic and system 900 design B) or polyamide (matching range 801), on both sides or on one side only. Provided the required minimum distances (see pages 31, 36) are complied with, the hinged support rails can be retrofitted at a later date.

The hinged support rails can be combined with the upgrade kit for the toilet flushing mechanism (radio controlled), if a sensor-controlled cistern is used (S50.02.02000, S50.02.02100 or S50.02.02200). A radio receiver (S50.02.02001) is also required for the sensor-controlled cistern. A backrest rail can be added to the hinged support rails of range 805 Classic and 801 (see p. 45). They are not available as mobile variants. The hinged support rails move with the toilet.

One add-on kit is required for each hinged support rail:

S50.02.00012 - left, seen from from user's view

S50.02.00013 - right, seen from the user's view

+ **S50.02.00002** - holder for mounting plate

Fixing material is included in the scope of supply.

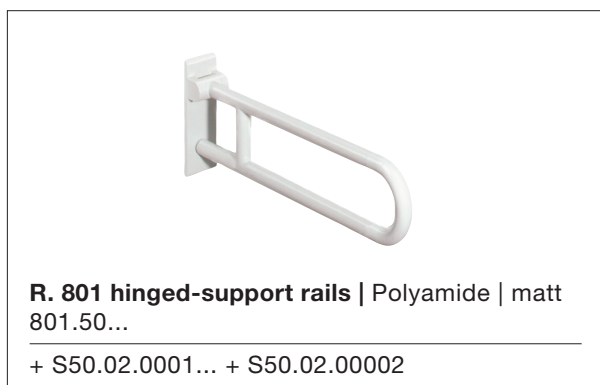
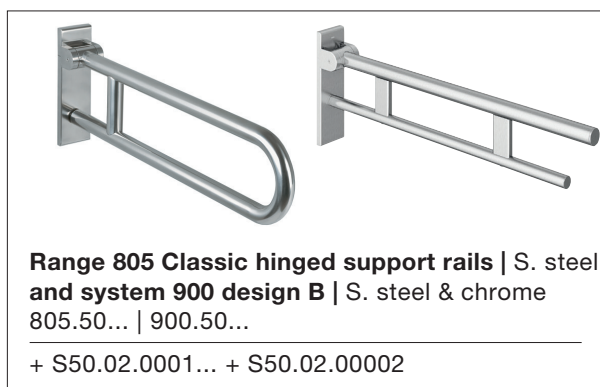

Backrest Rail | Range 805 Classic | Range 801

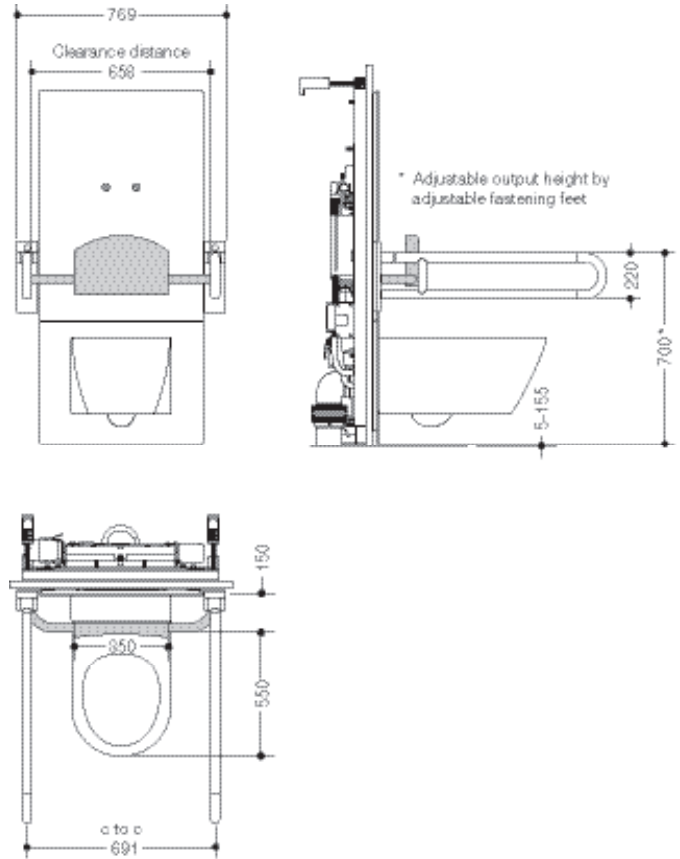

805.51.9... | 801.51.9...

The hinged support rails of range 805 Classic (stainless steel) and range 801 (polyamide and matt polyamide) can be combined with a backrest rail. The backrest rails have a padded rest made of PUR (...900) or backrest is made of synthetic material (...906 or ...907).

Range 801 backrest rail:

801.51.900 | 801.51B900 | 801.51D900

801.51.906.. | 801.51B906..

805.51.907.. | 801.51B907..

Fixing material BM11.2.1 - please order separately.

Range 805 Classic backrest rail:

805.51.900

805.51.906

805.51.907

Fixing material BM11.2.1 - please order separately.

Hinged Support Rails Add-On Kit | System 900 design A

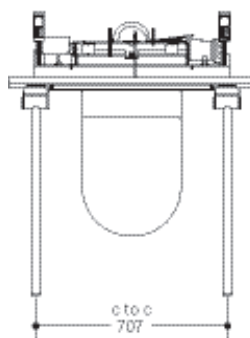
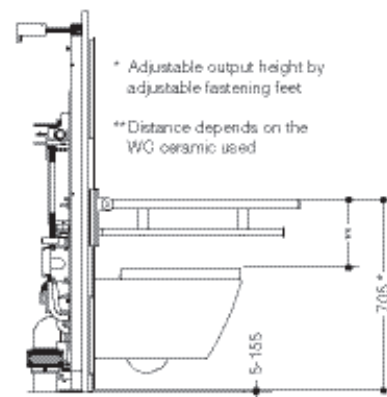
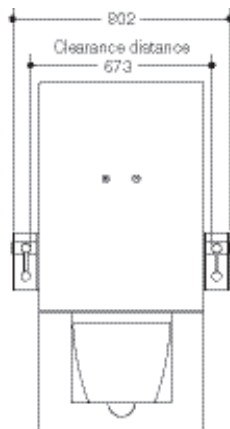

ADD-ON KIT S50.02.0004...

The toilet module can be equipped with system 900 design A hinged support rails on both sides or on one side only. Provided the required minimum distances (see pages 31, 36) are complied with, the hinged support rails can be retrofitted at a later date.

As an option, the hinged support rails are available with an integrated toilet flushing mechanism (radio-controlled). If this variant is selected, a sensor-controlled flushing tank must be used (S50.02.02000, S50.02.02100 or S50.02.02200). A radio receiver (S50.02.02001) is also required for the sensor-controlled

cistern. A backrest rail can be added to the hinged support rails of system 900 (see page 45). They are not available as mobile variants. The hinged support rails move with the toilet.

One add-on kit is required for each hinged support rail:

S50.02.00042 - left, seen from from user's view

S50.02.00043 - right, seen from the user's view

+ S50.02.00002 - holder for mounting plate

Fixing material is included in the scope of supply.

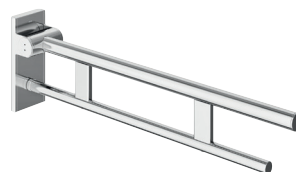

System 900 design A hinged-support rails |

Chrome

900.50....40

+ S50.02.0004... + S50.02.00002

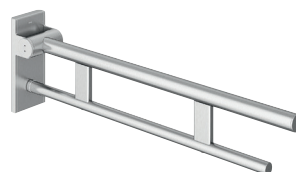

System 900 design A hinged-support rails |

Stainless steel

900.50....XA

+ S50.02.0004... + S50.02.00002

Backrest Rail | System 900 design A

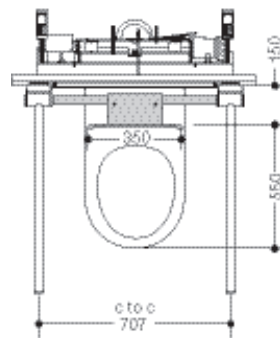
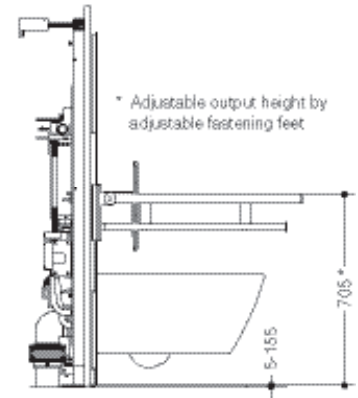
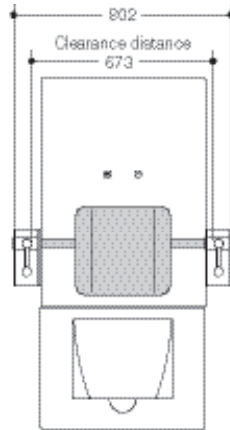

900.51.90...

The hinged support rails of system 900 design A (chrome/stainless steel) can be combined with a backrest rail.

The backrest is available in the HEWI colours 98 (signal white) or 92 (anthracite grey).

HEWI

www.hewi.com

GERMANY

HEWI Heinrich Wilke GmbH

Postfach 1260

34442 Bad Arolsen

Phone: +49 5691 82-0

Fax: +49 5691 82-319

international@hewi.com